



Closet System Installation Instructions

Copyright 2009 EasyClosets.com | Version 07.09

HOW TO READ THESE INSTRUCTIONS

SECTION 1. GETTING STARTED:

This section helps you identify the installation method your particular design requires, what basic tools are required and which are helpful, the hardware included with your order, and instructs how to quickly inventory your shipment to speed installation.

SECTION 2. BASIC INSTALLATION INSTRUCTIONS:

This section outlines the basic cabinet framework of vertical panels and cam shelves.

SECTION 3. INSTALLING CUSTOM CLOSET COMPONENTS:

This section provides detailed instructions for installing custom components, such as hampers, doors, slanted shoe shelves, etc.

SECTION 4. NON-STANDARD INSTALLATIONS:

This section provides detailed instructions for installing our closet system in unconventional situations.

SECTION 5. FINAL STEPS:

This section covers installation of adjustable shelves, rods and other finishing steps.

HOW TO READ YOUR WALL PLANS

HOW TO READ YOUR WALL PLANS:

We've included plans of all the closets you ordered. You'll find one elevation drawing for each wall of each closet in your order.



NOTE: Each Vertical Panel is 3/4" thick. This measurement is not included in the "Width" dimension.

SAMPLE WALL PLAN:

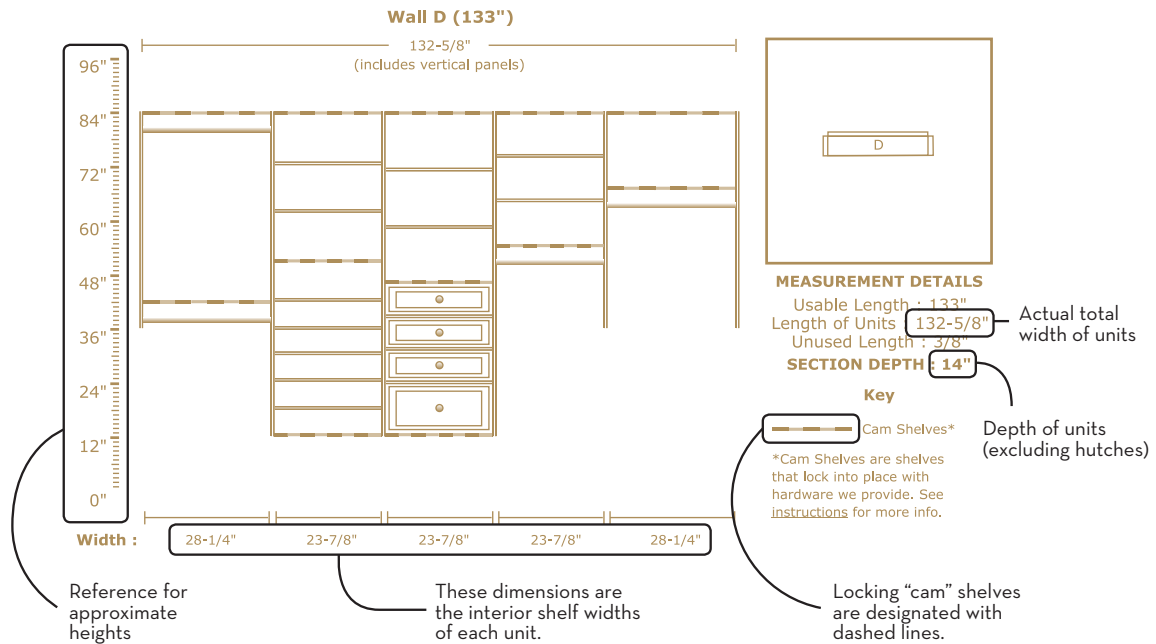

SECTION GUIDE

*Thank you for your purchase!
It is our desire to make your entire
experience from purchase
to installation as easy as possible.
We ask that you read each step of
this installation manual thoroughly to
ensure proper installation of your
new closet. Our lifetime guarantee
is based on following proper
installation techniques. Installing
your closet in any manner other than
the steps outlined in this manual
may lead to structural failure of
your closet.*



NOTE: Always install the track cover after your installation is complete.

Hanging your closet directly on top of the track cover will cause the material to fail and your closet to fall.

1. GETTING STARTED	
a. Four Basic Installation Scenarios	2
b. Required & Recommended Tools	3
c. Hardware Illustrations	3
d. Inventory Your Shipment & Remove Old Closet Material	4
2. BASIC INSTALLATION INSTRUCTIONS	
FLOOR-BASED & WALL-MOUNTED DESIGNS WITH TRACK	5
FLOOR-BASED DESIGNS WITHOUT TRACK	12
a. Floor-Based Units Attached to Wall	12
b. Free-Standing Floor-Based Units (Islands)	13
3. INSTALLING CUSTOM COMPONENTS	
a. Drawers	15
b. Drawer Lock	18
c. Baskets	19
d. Hampers	20
e. Slanted Shoe Shelves	21
f. Shelf-Mounted Ironing Board	22
g. Inside & Outside Corner Shelves	24
h. Connecting Shelves in Corners	25
i. Doors	26
j. Crown Molding	27
k. Pantry Items	28
4. NON-STANDARD INSTALLATIONS	
a. Pocket Doors	29
b. Sloped Ceilings	30
c. Cleats for Short & Tall Sections	30-31
d. Surrounding Wall Objects	31
5. FINAL STEPS	
a. Track Cover	32
b. Rods	32
c. Adjustable Shelves	32
d. Accessories	32
6. VERTICAL PANEL WORKSHEET	33

FOUR BASIC INSTALLATION METHODS

Refer to your particular design to identify which method(s) you should use.

WALL MOUNTED WITH TRACK (Page 5)

The vast majority of our organizers are hung off the floor from our steel track. It is important that the track be shimmed straight and anchored as instructed. Extra tall and very short cabinets require support cleats.

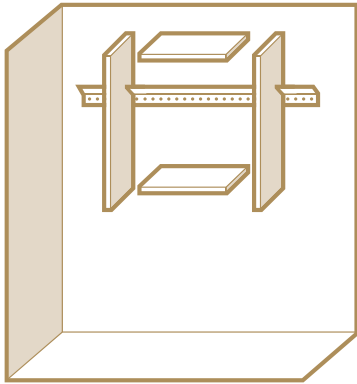

FLOOR MOUNTED WITH TRACK (Page 5)

Tall, floor mounted cabinets rest on the floor (or shims, if the floor is not level). The track anchors the tops of the cabinets and prevents them from tipping forward and from swaying or racking. Floor mounted units require careful track height positioning.

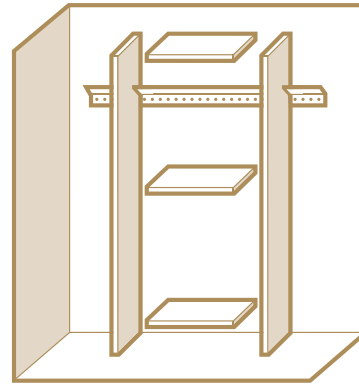

FLOOR MOUNTED WITH L-BRACKETS (Page 12)

Short, floor mounted cabinets rest on the floor (or shims, if the floor is not level). L-brackets anchor the cabinets to the wall, and prevent swaying and racking.

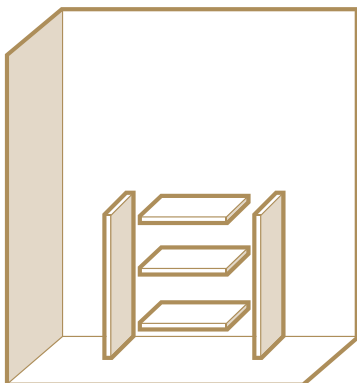

FREESTANDING (Page 13)

Islands and free standing cabinets rest on the floor (or shims, if the floor is not level). Backing is installed to brace the cabinets.

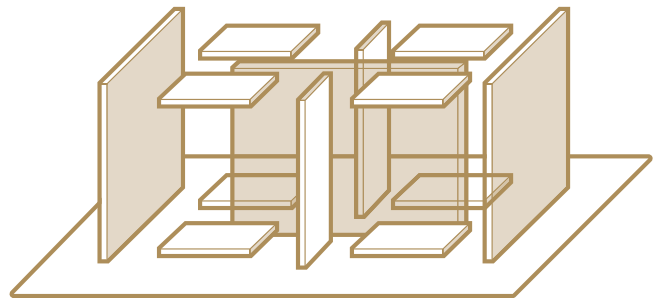

REQUIRED AND RECOMMENDED TOOLS

REQUIRED ITEMS:

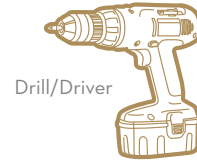
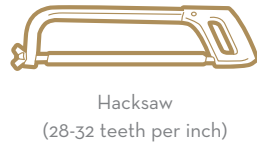
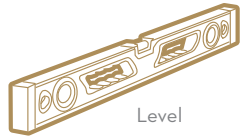
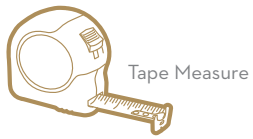

RECOMMENDED TOOLS (MAY BE HELPFUL FOR SOME INSTALLATIONS):

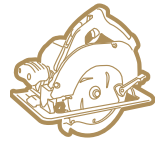
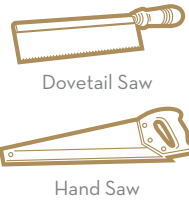
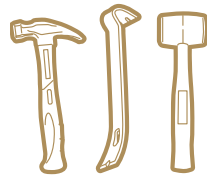

HARDWARE INCLUDED PER YOUR ORDER:

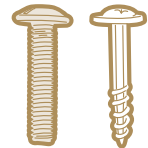
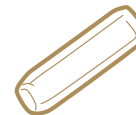
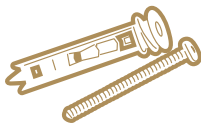

INVENTORY YOUR SHIPMENT & REMOVE OLD CLOSET MATERIAL PRIOR TO INSTALLATION!



IMPORTANT: Checking all of your inventory will ensure that you have all the materials you need before you start. It will also make the installation process run smoother and will help to prevent any delays along the way.

A. CHECK YOUR INVENTORY BEFORE BEGINNING INSTALLATION!

- (1) If you received your order via **delivery** or **freight carrier**, skip to step #4.
- (2) If you received your order via **UPS**, check that you have received all boxes in your shipment. Each box is labeled with a **Company Shipping Label** (see graphic below). Note each box as well as the total number of boxes in the shipment.



IMPORTANT!
Check off items as you take inventory. Extra material is packaging and filler. Please discard.

SHIPPING LABEL

Name: Smith, John
INVOICE #: 29930397003089

Box #: 7 of 36

QTY	COLOR	SIZE	DEPTH	DESCRIPTION	CLOSET
1	White	72"	14"	Vertical Panel	Mom's CL
1	White	72"	14"	Vertical Panel [Finished Right Side]	Mom's CL
1	White	72"	14"	Vertical Panel	Linen CL
2	White	72"		Steel Track	Master (copy 3)
2	White	72"		Steel Track Cover	Master (copy 3)

STATION ID: 3 BOX WEIGHT: 68 lbs #27# PREPACK_72_WHITE

Note specific box number.

Note total number of boxes in shipment.

Note closet to which item belongs.

- (3) **Open each box** and compare the contents against the itemized list on the Shipping Label. You may discover that we have included scrap boards of various sizes as fillers in the shipping cartons. These may be discarded.

- (4) **Organize the material** into like sizes. If there are multiple closets, you may prefer to separate the materials first by closet, based on the itemized list on the shipping labels.

- (5) **Take a full inventory.** Use either the "Complete Parts List," (as shown in the graphic to the right) or the "Parts List" for each closet as a checklist. Once all material has been inventoried, if any pieces are damaged or missing, please keep all packing material and contact **Post-Sales Support**. 1-800-910-0129 (menu option 5)

COMPLETE PART LIST

ORDER SUMMARY										
Client Name: Example Person										
Invoice #: 00000000000000										
VERTICALS					DRAWER BOXES					
Qty	Name	Height	Depth	Color	Qty	Name	Width	Height	Depth	
5	Vertical Panel	72	14	White	84	#6 - 5/8" screws				
6	Radius Vertical Panel	48	14	White	10	14" Full Extension Drawer Glides (PAIR)				
1	Radius Vertical Panel	24	14	White	80	Cam Fittings			White Plastic	
REGULAR SHELVES					DRAWER / HAMPER FACES					
4	Connector Brackets				1	Drawer Face (Raised Panel) (Pre-Drilled for Knobs)	29 7/8	12	White	
2	Regular Shelf	29 7/8	14	White	3	Drawer Face (Raised Panel) (Pre-Drilled for Knobs)	29 7/8	8	White	
8	Regular Shelf	23 7/8	14	White	1	Drawer Face (Raised Panel) (Pre-Drilled for Knobs)	29 7/8	5	White	
CAM SHELVES					RODS					
2	Cam Shelf	30 3/8	14	White	2	Hanging Rod	30 5/8		Polished Chrome	
4	Cam Shelf	30 3/8	14	White	4	Hanging Rod	30 1/8		Polished Chrome	
3	Cam Shelf	29 7/8	14	White	4	Hanging Rod	26 5/8		Polished Chrome	
4	Cam Shelf	26 7/8	14	White	1	Hanging Rod	23 5/8		Polished Chrome	
7	Cam Shelf	23 7/8	14	White	ACCESSORIES					
1	Half Cam - Left	10 3/8	14	White	1	Tie Back			Polished Chrome	
1	Half Cam - Right	10 3/8	14	White						
DRAWER / HAMPER FACES					DRAWER BOXES					
4	Drawer Face (Raised Panel) (Pre-Drilled for Knobs)	23 7/8	8	White	1	Drawer Box	White	29 7/8	12	14
					3	Drawer Box	White	29 7/8	8	14
					1	Drawer Box	White	29 7/8	5	14
					1	Drawer Box	White	23 7/8	12	14
					4	Drawer Box	White	23 7/8	8	14

B. REMOVE OLD CLOSET MATERIAL

- (1) Remove the existing closet rods, shelves and shelf supports.
- (2) If desired, fill holes with spackling and repaint closet. As you fill in the holes, mark these locations, as they often mark the locations of the studs.

FLOOR-BASED & WALL MOUNTED DESIGNS WITH TRACK



IMPORTANT: Read the following instructions carefully! The track installation is the most critical part of a closet installation.

A. LAYOUT & TRACK MEASUREMENT

- (1) **PLAN YOUR TRACK LAYOUT:** Review the plans we've provided for your closet. You will need to run our track behind all of the units in your closet. When installing our units on multiple walls in your closet, you will want to determine which units will run into the corners and which units stop short of the corners. Track can be run past an end panel, but must stop short of a unit on an adjacent wall. Please check your invoice for any special customer notes. You will establish track lengths in Step 5 of this section.
- (2) **DETERMINE TRACK HEIGHT:** If your closet design includes floor-based sections, such as a hutch, we recommend that you install these units first. The height of the vertical panel notch establishes the height of the track and top shelf for the remainder of the closet.



IMPORTANT: If all your vertical panels go to the floor, then you must find the high spot on your floor first.



IMPORTANT: If none of your vertical panels go to the floor, then skip to (2b): DETERMINE YOUR TRACK HEIGHT FOR WALL-MOUNTED UNITS.

(a) DETERMINE TRACK HEIGHT FOR FLOOR BASED UNITS:

Set your vertical panel on the high spot of your floor against the wall, and mark where the top of the panel meets the wall. Measure down 8-3/8" from this point, and draw a level line to mark the track height. Transfer and continue the track line to each wall on which units will be installed. Install the track with its bottom edge on this line. **Sloped ceilings and staggered top shelf heights require multiple track heights. See page 31 for instructions.**



NOTE: Floor based units may require removal of baseboard molding or notching for baseboard molding. Only hutch vertical panels are pre-cut to accommodate most common baseboard moldings.



IMPORTANT: You must correctly identify whether your design consists of floor-based, wall-mounted or a combination before establishing track height.

Sample Plan & Track Layout

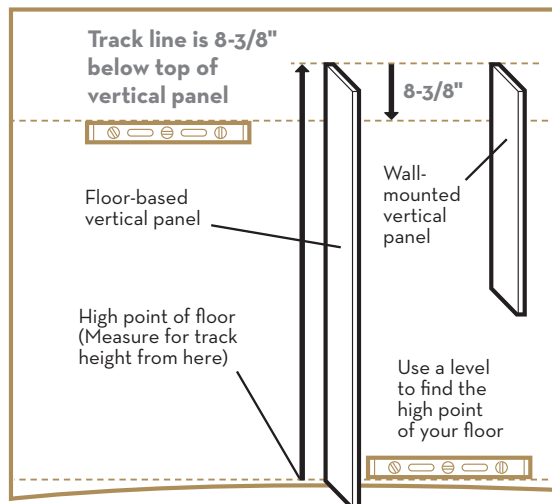
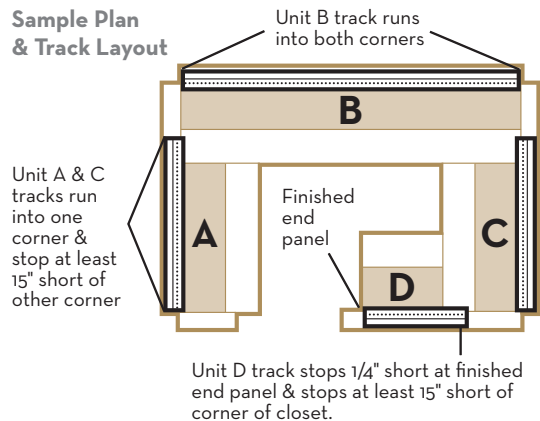

FLOOR-BASED & WALL MOUNTED DESIGNS WITH TRACK

PREPARE FLOOR-BASED VERTICAL PANELS AND SHELVES

If you elect not to remove baseboard molding and your molding height exceeds 3-1/2", then some additional cutting will be necessary to properly position hutch vertical panels and other vertical panels against the walls of your closet. You will also need to trim off the back edge of the bottom cam shelves in the amount of the molding's thickness. Use a dovetail saw, jigsaw or other fine-tooth saw to enlarge the baseboard cutout. Use a circular saw or table saw to trim the cam shelf. This trimmed shelf will be hidden beneath the drawers in a hutch unit.

Floor-based vertical panel

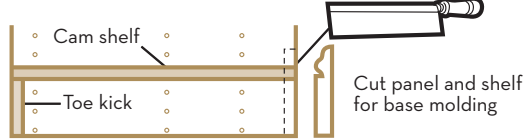

Bottom of vertical panel requires additional cutting for baseboard molding. Rear of cam shelf may also require trimming if molding is tall.



NOTE: We strongly recommend that you remove your baseboard molding, if you have floor-based units. After installing your closet, reinstall pieces of the trim over any areas not covered by the closet.

(b) DETERMINE YOUR TRACK HEIGHT FOR WALL-MOUNTED UNITS:

The bottom edge of the track will always be 8-3/8" lower than the top of the top shelf. For example, for a standard 84" top shelf design, the bottom edge of the track would be installed at 75-5/8" from the floor. Draw a level line to mark the track height. Transfer and continue the track line to each wall on which units will be installed. **Staggered top shelf heights require multiple track heights. See page 31 for instructions.**

(3) LOCATE AND MARK STUDS:

Locate and mark all studs (X) along each track line. **(Note: Standard 2" x 4" studs are usually located 16" on center measured from the left or right end of the wall.)** Use a stud finder, or tap the wall & listen to locate stud. Confirm location by lightly driving a finishing nail or small screw above line. Any holes will be covered by the track. Once the first stud is found, measure over 16" for the next stud.

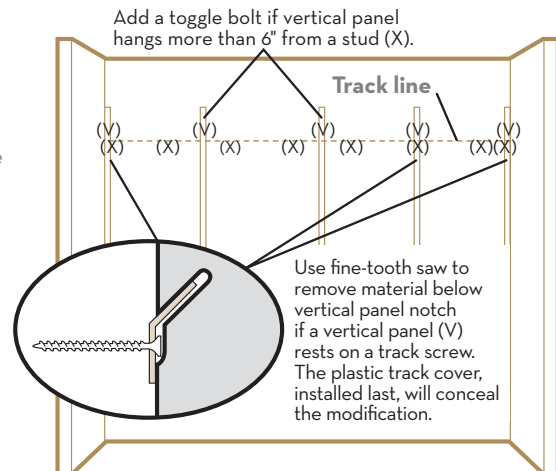

Mark vertical panel and stud locations

(4) MARK EACH VERTICAL PANEL LOCATION:

Mark the approximate location of each vertical panel (V) by referring to each unit wall plan. Note that vertical panels are 3/4" thick and section interior widths are indicated below each wall plan. **Note, if one of your vertical panel locations will fall directly on top of an installed track screw, it is necessary to remove material below the notch using your hacksaw or other fine-tooth saw, so that the vertical panel sits all the way down on the track and does not rest on the track screw.**

(5) ESTABLISH TRACK LENGTHS:

After determining the width of each unit in your design and the location of wood studs, cut your track to length using a hacksaw. Refer to the "Length of Units" measurement on the right side of each wall drawing in your design. **This is the typical length of your track for the wall.**



IMPORTANT: Read all of Step 5 before cutting steel track.

FLOOR-BASED & WALL MOUNTED DESIGNS WITH TRACK

However, this is subject to a few important considerations. For example, if you have:

(a) WALK-IN CLOSETS: If a unit does not end in a corner or at a stud, the track must be secured by running the track past the end vertical panel to the next stud or by securing the end of the track with E-Z toggles at the 2nd and 5th holes from the end. **(IMPORTANT: Never use substitutes for our E-Z toggles! Plastic anchors or “Molly Bolts” will not work!)**

(b) FINISHED END PANELS: If any vertical panel is marked as “Finished,” subtract 1/4” from the track length. **(Finished ends only have partially cut notches.)**

(c) UNITS GREATER THAN 72” WIDE: If the “Length of Units” measurement is greater than 72”, you will need two or more pieces of track. Each piece of track must be long enough to be secured into a minimum of two studs for adequate strength. Choose an appropriate stud at which to have two pieces of track meet. This means that you may have to cut each piece of track rather than using any 72” pieces. Align the butted end of each track over the stud so that each end can be screwed into the shared stud by angling the track screw.

RADIUS INSIDE & OUTSIDE CORNER SHELVES: See page 24.

B. INSTALL THE TRACKS

NOTE: This section assumes that you have 2"x4" wood studs in your walls.

OTHER WALL TYPES

- (1) Metal Studs:** This wall type requires E-Z toggles which are provided if you selected the metal studs wall type in the design tool. Install E-Z toggles every 6"-8" avoiding the metal studs. Use two toggle bolts near each track end in the 2nd and 5th track holes.
- (2) Masonry Walls:** This wall type requires masonry screws which are provided if you selected the concrete wall type in the design tool. Install masonry screws every 8" and at each track end.

Track Installation

- a. **Position track and mark wall through track holes** where toggles or masonry screws are required. Set track aside.
- b. **Install toggles (see page 8) or drill masonry** using the 5/32" masonry drill bit provided.
- c. **Anchor track** using toggle or masonry screws.

CAUTION: Over tightening toggle bolts will crush and weaken drywall. Over tightening masonry screws will strip out hole and reduce holding power of screws.

- (1) TRACKS WITHOUT E-Z TOGGLES:** If, after marking the stud and vertical panel locations, there is a wood stud within 6" of each vertical panel for your plan, and each track end is secured to a wood stud, you can mount the track using only the black track screws included with your kit. Drive black track screws through the track into every wood stud. **IMPORTANT: We recommend 2 screws per stud where possible. DO NOT SUBSTITUTE. HINT: Lubricate screws on a bar of soap or candle to ease driving. Angle screws if necessary.**

- (2) TRACKS WITH E-Z TOGGLES: IMPORTANT: Install black track screws into available studs at all locations. We recommend two screws per stud where possible.** E-Z Toggles are required whenever a vertical panel is more than 6" from a wood stud or a track end does not coincide with a wood stud location. Determine the E-Z Toggle locations by holding the track on the track height line on the wall. Mark track hole locations near vertical panels requiring E-Z Toggle support (within 2" of vertical panel). Also, where a track does not end at a stud, mark the 2nd and 5th holes from the end of the track. Set track aside. Drive E-Z Toggles into pre-marked locations using a Phillips screwdriver. Press into drywall while turning the anchor clockwise until it is seated flush with the wall and arrows on head are parallel to the stud. Place track in position over E-Z Toggles. Insert E-Z Toggle screw through track into E-Z Toggle and strike screw to deploy toggle clamp. Turn E-Z Toggle screw until tight. The clamp will draw tight to the drywall as the screw turns. **IMPORTANT: Never use substitutes for our E-Z Toggles! Plastic anchors or “Molly Bolts” will not work!**

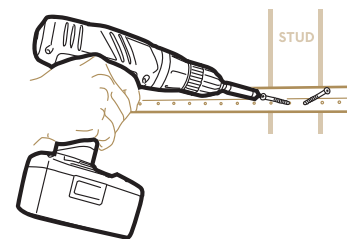

FLOOR-BASED & WALL MOUNTED DESIGNS WITH TRACK

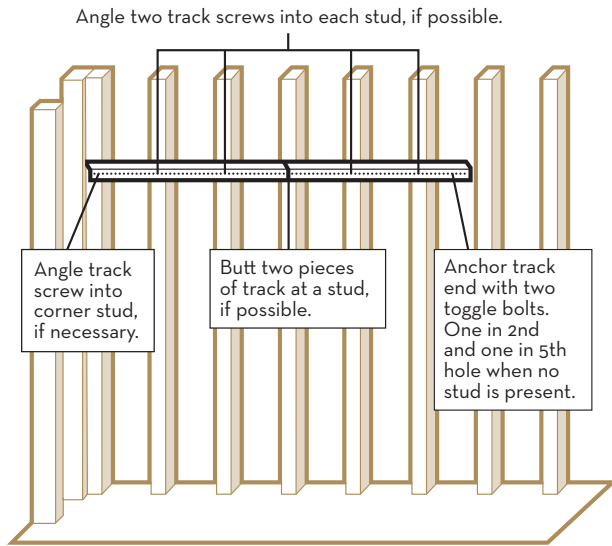

Metal Studs? Use toggle bolts every 6-8".
Masonry Walls? Use masonry screws every 8".

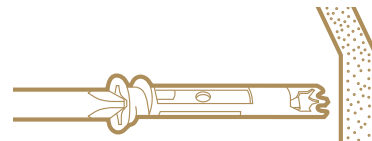

Drive E-Z Toggle into drywall.

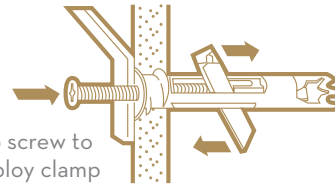

Tap screw to deploy clamp

You will have to turn screw 20-25 complete revolutions to tighten toggle clamp

Do not over tighten or the drywall will be weakened.



IMPORTANT: Do not leave end of track unsupported. It must be secured either into a stud or with a minimum of two toggle bolts in the 2nd and 5th holes.



VERY IMPORTANT: Do not install track cover on your track. This will be the final installation step. Installing it at this stage will cause your closet to fall.

- (3) **MAKE SURE THE TRACK IS STRAIGHT:** It is important to check that the track is reasonably straight. The track must conform to our shelving system and not to an imperfect wall. Use a long straight edge, such as a 4 foot level or a vertical panel, to locate any hollows or bulges in the wall. Wherever the wall hollows, loosen the track screws, insert shims between the track and the wall and retighten the track screws. Shims may be any solid, thin material. Another sign indicating that shimming is necessary is experiencing difficulty drawing the cam shelves and vertical panels together later in the installation. **NOTE: Failure to shim the track on a wavy wall will cause the vertical panel notches to break.**

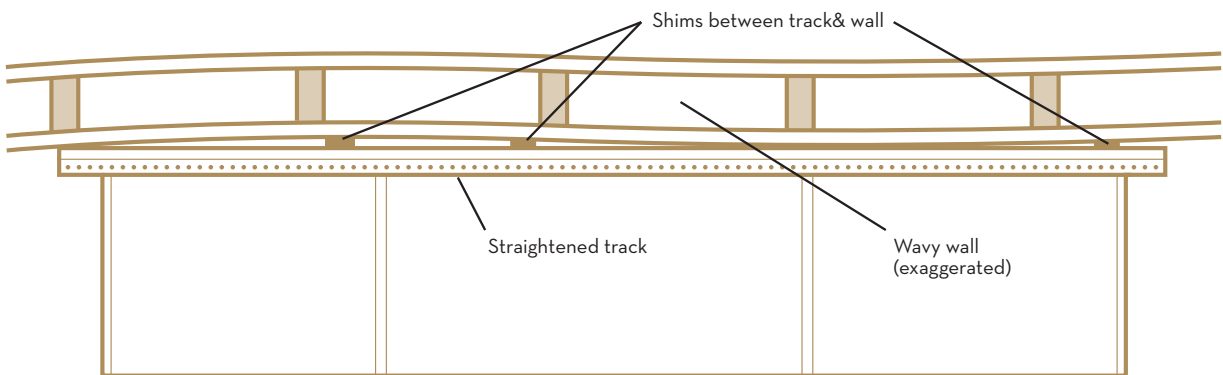

Overhead view of a wavy wall & shimmed track.

INSTALL VERTICAL PANELS & SHELVES

(1) HANG VERTICAL PANELS:

Hang notched vertical panels from steel track at your marked locations. When adjusting the placement of the verticals on the track, lift up to move.

Do not push or slide a vertical along the track.

Finished end panels are provided and noted on your plans where end panels are exposed.

You may have to place shims beneath floor-based vertical panels if your floor is not level.

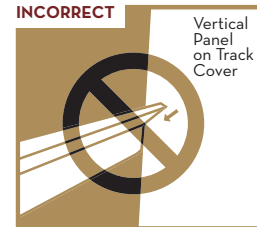
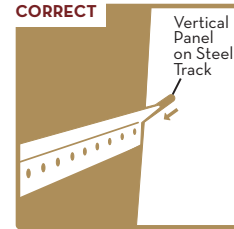
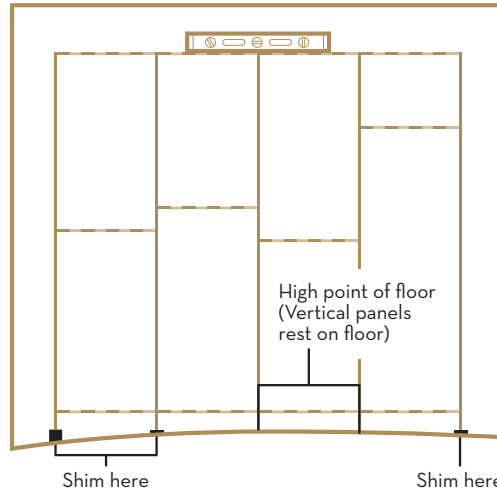

(2) DETERMINE CAM SHELF LOCATIONS:

Cam shelves are required at the top of each vertical, at the bottom of shelving sections, above and below drawer sections and in the middle of full-height shelving units. Read ahead to learn where cam shelves are positioned in relation to rods, baskets and other elements. Some cam shelves must be located precisely while others may be located according to preference.

TIP: Use shelf pins and rod ends as place holders to layout shelf and locations before installing cam screws.

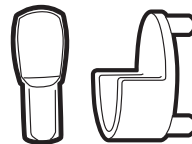

TIP: Install single and double cam screws in the top holes of the vertical panels before hanging.



Use the helpful **Vertical Panel Worksheet** on page 33 to layout cam shelf locations and other components.

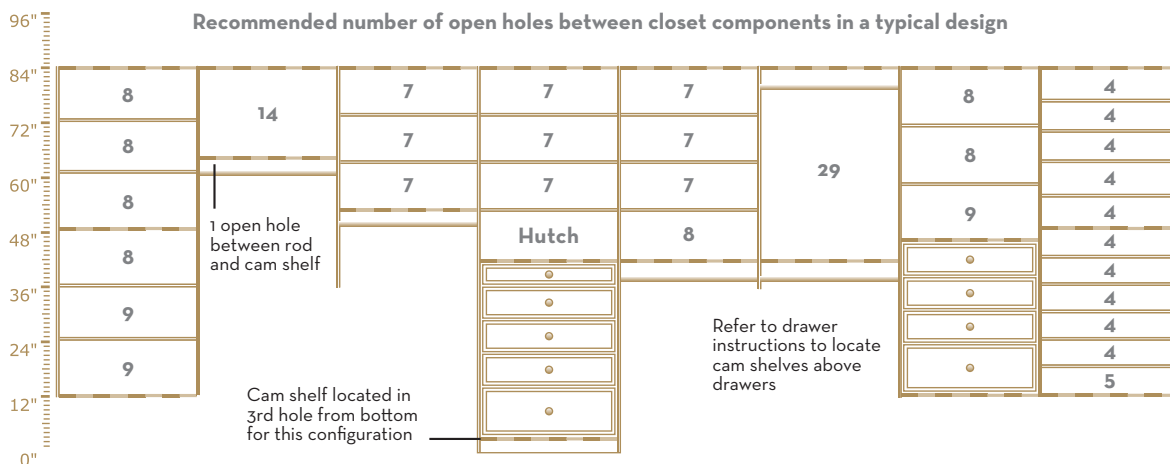

(a) HUTCH CAM SHELVES/LOW CAM SHELVES: 19" deep cam shelves go above the top and below the bottom hutch drawers. The cam shelf above the top drawer should be installed in the top hole in the lower section of the hutch vertical panel. The bottom cam shelf below the drawers should be installed at the appropriate height, depending on the drawer combination, to sit directly on top of the toe kick provided. (Refer to nearby table).

COMBO OF DRAWERS	TOE KICK HEIGHT	CAM POSITION
(1) 5", (3) 8", (1) 12"	2-1/2"	3rd Hole
(5) 8"	3-3/4"	4th Hole
(2) 8", (2) 12"	3-3/4"	4th Hole

(3) INSERT CAM FITTINGS AND CAM SCREWS: Tap plastic cam fittings into shelves drilled for cams with a hammer or mallet. Install cam screws into holes in verticals where cam shelves are required. (See nearby illustrations).

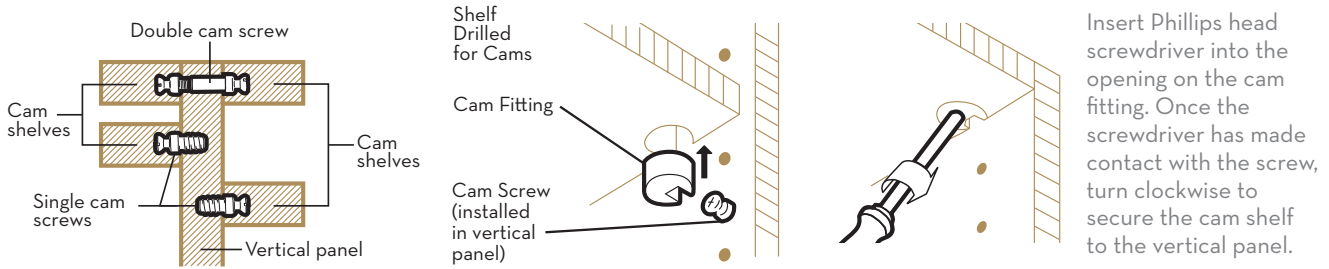

Double Cam Screws are required in locations where cam shelves are positioned on both sides of a vertical at the same height. Single Cam Screws are used in all other cam shelf locations. (See Figure)



For best results, use a #2 Pozidrive bit (PZ2) to drive cam screws. Otherwise, use a #2 Phillips bit.

TIP: Use the SLOW SPEED and LOW TORQUE settings on your drill when installing cam screws.

(4) INSTALL THE CAM SHELVES:

Install **cam shelf** by placing shelf with cam fittings on cam screws. Lock cam fittings by turning them clockwise 90 degrees with a Phillips head screwdriver. Cam fittings should turn easily. **DO NOT FORCE.** If the front or rear cam fittings will not easily lock, you may need to straighten the track by shimming. **Go back to the section, "Make sure the track is straight".**

TIP: The bottom cam shelf for a floor-based unit can be installed upside-down (cam fittings on top) to allow for easy access to lock cam fittings. Or, the rear of the cam shelf can be first lowered onto the rear cam screws and locked while the front of the shelf is tipped up as if it were a trunk lid, and then the front of the shelf can be lowered onto the front cam fittings to lock them. Pull the vertical panel slightly away from the wall to avoid scraping the wall as you lower the cam shelf.

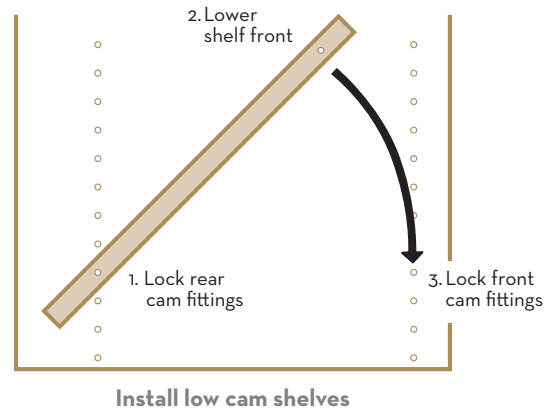

INSTALL TOE KICKS

If your design includes toe kicks, position toe kicks under bottom cam shelves flush to the front or slightly set back. Drill $3/16$ " holes through cam shelf only, 4" from each end and in the center. Drive 2" screws through holes into toe kicks until screws are flush or slightly countersunk.

Alternatively, toe kicks may be installed with a brad nailer, or by pushing the toe kick back against some stops that you provide and install.

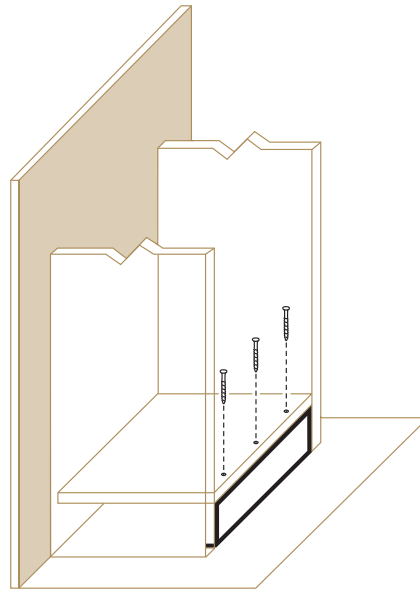

L-brackets below
or inside cabinet



NOTE: "L" brackets are supplied to install below any "single" or stand-alone sections to prevent any side-to-side movement. To install "L" bracket, simply attach underneath bottom cam shelf with $5/8$ " screws and to stud in wall with 2" screws. If no stud is available, use E-Z Toggle into sheetrock.

FLOOR-BASED DESIGNS WITHOUT TRACK

A. FLOOR-BASED UNITS ATTACHED TO WALL WITHOUT TRACK

NOTE: Floor-based units may require removal of baseboard molding or notching of vertical panels. See **Prepare Floor-Based Vertical Panels And Shelves** in previous section.

- (1) **Assemble one section.** Assemble a section with two vertical panels and the required cam shelves on its back. Refer to **Install Vertical Panels & Shelves, steps 2 - 4** in the previous section.
- (2) **Position section.** Carefully tip section upright and move into position. **CAUTION: When moving section into position, be careful not to rack the cabinet, or damage to the cam connections may result.**
- (3) **Assemble additional sections, if any.** If your floor-based design consists of a multi-section unit, install the cam shelves and vertical panels of the adjacent sections.
- (4) **Anchor unit.** Ensure cabinet is square using a carpenter's square or by measuring the diagonals. (The diagonals will be equal if the cabinet is square.) Attach L-brackets to studs in the wall with 2" screws or to EZ Toggles, and to the underside of the top cam shelf with 5/8" screws. You may also anchor the bottom cam shelf to studs.
- (5) **Install toe kicks.** Refer to **Install Toe Kicks** in the **Install Vertical Panels & Shelves** section.

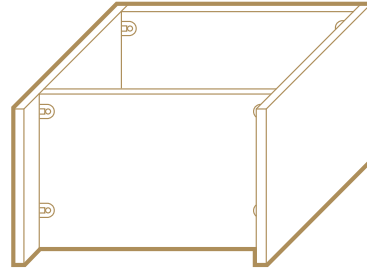

Assemble floor-based unit on its back.

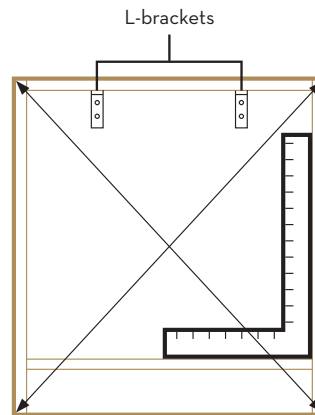

Make sure cabinet is square.
Anchor unit with L-brackets.

ISLANDS & FLOOR-BASED DESIGNS WITHOUT TRACK

B. FREE-STANDING FLOOR-BASED UNITS (ISLANDS)

- (1) **Assemble one-sided island or one side of double-sided island** as described in steps 1 & 2 of previous section.
- (2) **Install island backing:** The island backing will prevent the island from racking side-to-side. Pre-drill $\frac{3}{16}$ " diameter holes through backing only and secure using 2" screws through the backing into the top and bottom cam shelves.
- (3) **Install second side of island (if applicable):** Install vertical panel(s) and cam shelves on second side of double-sided island.
- (4) **Install toe kicks.** Refer to **Install Toe Kicks** in the Install Vertical Panels & Shelves section.

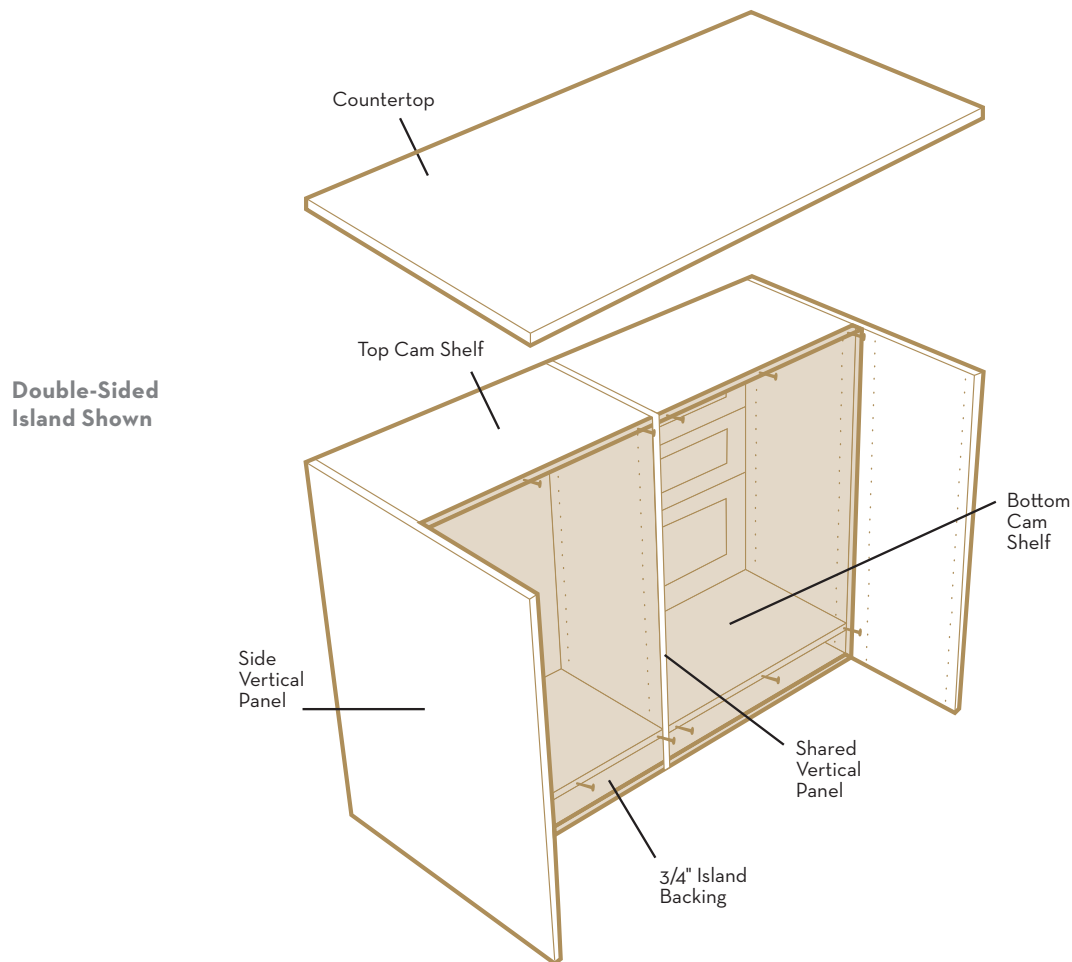

- (5) **Install countertop (if included with your design)** by driving $1\frac{1}{4}$ " screws through top cam shelves from below. Drill $\frac{3}{16}$ " diameter holes thru the top cam shelves to allow the screws to draw the countertop down tight.

Alternatively, you can lay a bead of caulking around the top of the island and set the countertop on it. You do not need a lot of caulking, just squeeze lines, squiggles or dots 1"-2" from the edges. Lightly clamp the countertop or use masking tape to hold it in place while the caulking cures.

INSTALL CUSTOM CLOSET COMPONENTS

Now that you have assembled the basic cabinets, you can begin installing your custom closet components (any drawers, baskets, hampers, doors, slanted shoe shelves or other items that are unique to your closet). Refer to the page numbers below to find the instructions for the component(s) you have in your closet. After you have installed your custom closet components, turn to page 32 for the final steps of your closet installation.

INSTALLING CUSTOM CLOSET COMPONENTS

- a. Drawers 15
- k. Drawer Lock 18
- b. Baskets 19
- c. Hampers 20
- e. Slanted Shoe Shelves 21
- f. Shelf-Mounted Ironing Board 22
- g. Inside & Outside Corner Shelves 24
- h. Connecting Shelves in Corners 25
- i. Doors 26
- j. Crown Molding 27
- k. Pantry Items 28
- * Countertops (see Island Instructions) 13

DRAWERS

A. ATTACH DRAWER FACE

- (1) **ATTACH HANDLES OR KNOBS:** Attach handle or knob to drawer face using the drawer handle screw(s) provided. (See Figure) Use black 1-1/4" screws for white and ivory handles. Occasionally, the recessed hole may be too deep and the screw will seem too long. A small washer or two will serve as a shim, and correct this problem. Do not force a knob or handle screw.

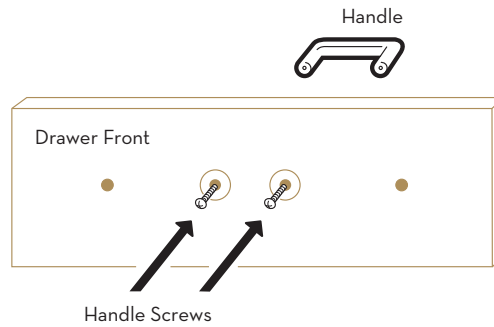

(2) ATTACH DRAWER FRONT TO DRAWER BOX:

Place drawer box on an adjustable shelf on a work surface. Attach drawer front to drawer box using the 1" drawer face adjuster screws. This way the drawer face will hang approximately 3/4" below drawer box. **Do not use power drill or power screwdriver!** Use manual screwdriver. Do not fully tighten the face to the box. You may need to adjust the drawer faces for proper leveling and spacing once all of the drawers are installed.

If you ordered full extension glides, attach them to the drawer box now. See next section.

TIP: Have a paper towel handy. Full extension glides are lightly lubricated.

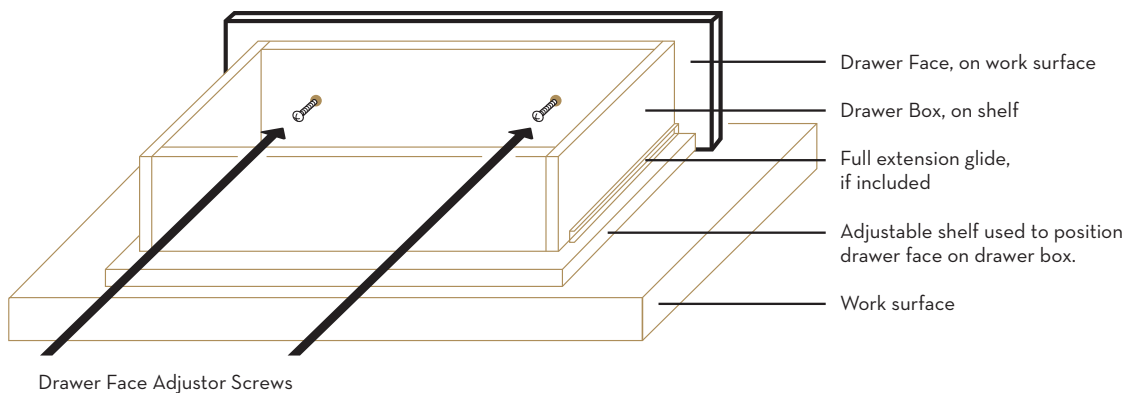

DRAWERS

B. ATTACH DRAWER GLIDES TO DRAWER BOXES

IF YOUR ORDER INCLUDES FULL-EXTENSION GLIDES (SILVER, BALL-BEARING):

(1) FIRST DISASSEMBLE YOUR FULL-EXTENSION GLIDES:

To disassemble the glide, fully extend the glide. Then press the black release tab and pull each end in an opposite direction to separate. (See Figure)

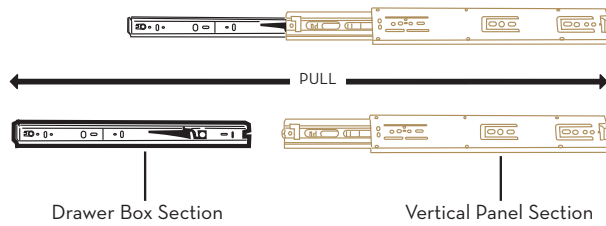

(2) ATTACH SMALLER GLIDE SECTION TO DRAWER BOX:

Position glide on the side of the drawer box, flush to the bottom and front. Using three (#6) 5/8" screws, secure the glide to the box through mounting holes near the front, center and rear of the glide.

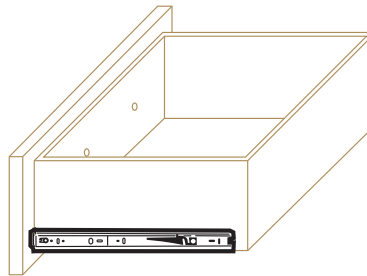

IF YOUR ORDER INCLUDES 3/4 EXTENSION GLIDES (WHITE, NYLON WHEELS):

(1) TURN DRAWER UPSIDE DOWN.

(2) IDENTIFY DRAWER MEMBERS.:

These drawer glides consist of right and left drawer members (DR & DL), and right and left cabinet members (CR & CL). These letters are usually stamped on the slides themselves.



(3) ATTACH THE RIGHT AND LEFT DRAWER MEMBERS:

With the box upside-down, position the glides to the bottom, side edges of the drawer box, flush to the face with the wheel to the rear of the drawer. Attach the drawer members (DR & DL) using two (#6) 5/8" screws for each. (See Figure)

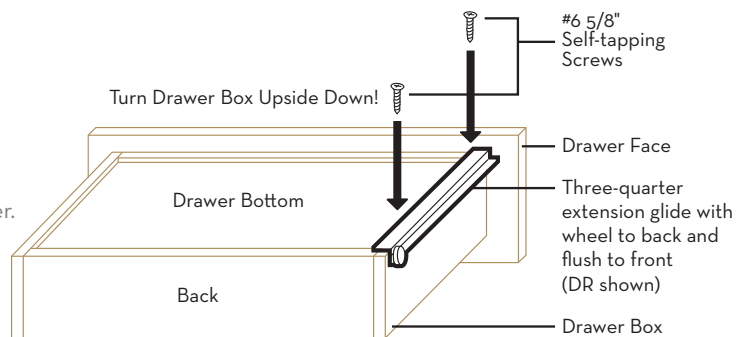

DRAWERS

C. ATTACH DRAWER GLIDES TO VERTICAL PANELS

While many closet components can be positioned at your discretion, drawer locations are often strictly determined by the design. Follow the guidelines in the next illustration to install the cabinet section of the glides, **beginning with the glides for the bottom drawer.** The guidelines apply to all drawer installations. (Full extension glides shown.)

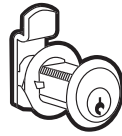

NOTE: Locking drawers require a special slotted, locking drawer, cam shelf. Refer to the **Drawer Lock** section of this manual now if you have purchased locking drawers.

Cam shelf above top drawer is located:

- in the 3rd hole above the glide if it is a 5" drawer (shown)
- in the 5th hole above the glide if it is an 8" drawer
- in the 8th hole above the glide if it is a 12" drawer

Glide above a 5" drawer is located in the 4th hole above the previous glide.

Glide above an 8" drawer is located in the 6th hole above the previous glide.

Glide above a 12" drawer is located in the 9th hole above the previous glide.

Glide for bottom drawer is located in the 1st open hole above the bottom cam shelf.

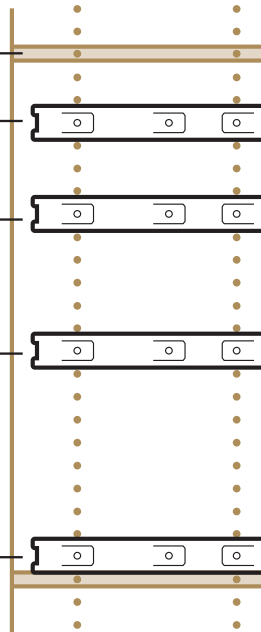

Attach glides to vertical panels with Euro screws

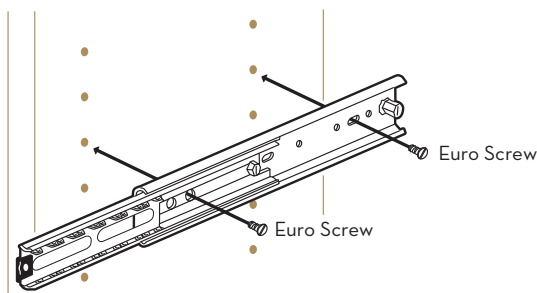

Full Extension Glide

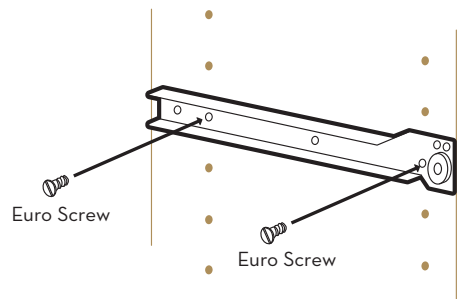

3/4 Extension Glide

DRAWERS

D. INSERT DRAWERS INTO UNIT

(1) STANDARD GLIDES:

Insert drawer so drawer box glide wheel is positioned behind cabinet glide wheel. Then push drawer in. It should glide freely.

(2) FULL EXTENSION GLIDES:

Carefully insert drawer straight so that drawer box and cabinet glide components engage. Push the drawer in. The last few inches will require extra force only when installing. Check that the glides move smoothly. If they do not, then it is possible the glide parts were not mated properly. Carefully reinstall.

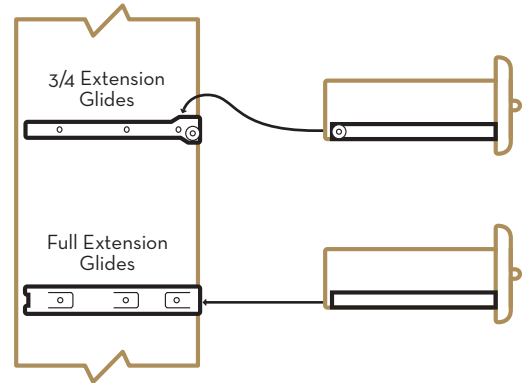

E. ADJUST DRAWER FACES

Oversized drawer box mounting holes allow the drawer face to be adjusted upwards, downwards, sideways and even rotated.

(1) LEVEL THE TOP DRAWER FACE:

Loosen the drawer face adjuster screws and adjust the top drawer face so that it is parallel to the top cam shelf. Once aligned, fully tighten the drawer face adjuster screws.

NOTE: Never use a power drill to tighten drawer face screws!

Always use a manual screwdriver.

(2) EXAMINE SHADOWLINE:

For the drawer below, examine the shadow line between the top of this drawer face and the bottom of the drawer face above. Adjust the face so that the gap is uniform across the width of the face - approximately 1/8".

(3) REPEAT STEP FOR EACH ADDITIONAL DRAWER.

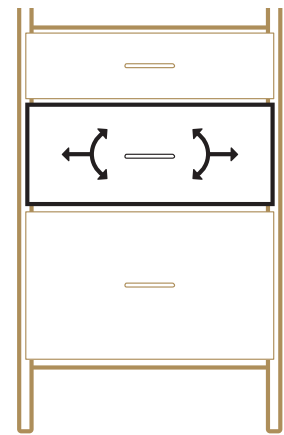

DRAWER LOCK

TO INSTALL DRAWER LOCK:

Our locking drawer comes with a pre-drilled drawer face and pre-notched drawer box, cylinder lock and specially routed drawer cam shelf with lock groove. Fully assemble and install drawer using the standard method (see page 15). Assemble and install the lock using the graphics at right:

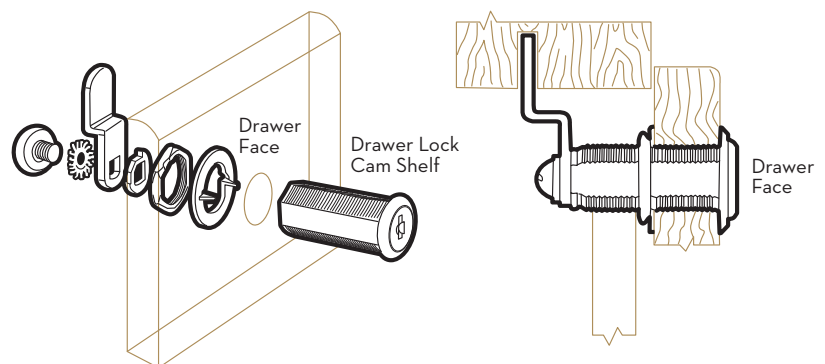

BASKETS

ALL BASKETS:

TO ATTACH FULL-EXTENSION GLIDES (STEEL):

1. **The first step in attaching your full-extension glides is disassembling the glide.** To disassemble the glide, first fully extend the glide. Then press the black plastic tab between the arrows with your thumb, and pull the smallest section completely out. (See Figure 1.)
2. **Install smaller glide section onto vertical panel with the closed end toward wall.** The black release tab is towards the front of the glide section. Set the glide 7/8" back from the front of the vertical panel and attach the glide using two Euro screws in the pre-drilled holes.



NOTE: Basket glides are compatible with the pre-drilled holes in 14" vertical panels only. For other depths, you are required to drill at least the rear mounting holes for the basket glides in the vertical panels.

Figure 1.

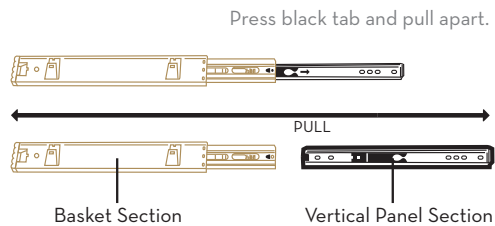

FOR RATTAN BASKETS ONLY: (See Figure 2.)

1. **Hook glide onto basket.** Hook the large glide section onto the basket with the bumper towards the front.
2. **Insert basket.** Insert basket section into the installed glides on the verticals.

FOR WIRE BASKETS ONLY: (See Figure 3.)

1. **Insert glides.** Insert large glide section into the installed glides on the verticals.
2. **Make sure they move smoothly.** Push firmly to engage the ball bearings. Once fully inserted, pull glides out to make sure that they move smoothly.
3. **Hang baskets.** Hang baskets from **second rung** onto glide hooks.
4. **Optional:** Slide rubber keepers over the tops of the glide hooks to semi-permanently install basket.

Figure 2.

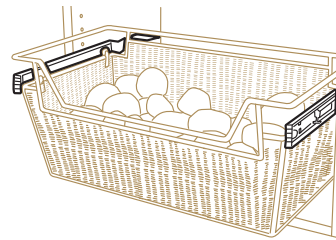
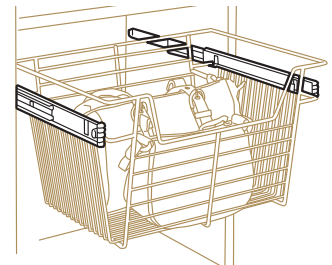

Figure 3.



ADDITIONAL GUIDELINES FOR BASKETS:

Baskets may be installed according to your preferences with regard to height and spacing. However, we can offer the following guidelines:

- A. If a basket is installed just below a cam shelf, allow at least 2 open holes between the basket glide and the cam shelf.
- B. If a basket is installed directly over the floor or a cam shelf,
 1. allow at least 16 3/8" or 12 open holes below the center of glide for a 17" basket
 2. allow at least 10 1/8" or 7 open holes below the center of glide for an 11" basket
 3. allow at least 3 3/4" or 2 open holes below the center of glide for a 6" basket
- C. If a basket is installed directly over another basket,
 1. allow at least 15 open holes between glides for a 17" basket
 2. allow at least 9 open holes between glides for an 11" basket
 3. allow at least 5 open holes between glides for a 6" basket

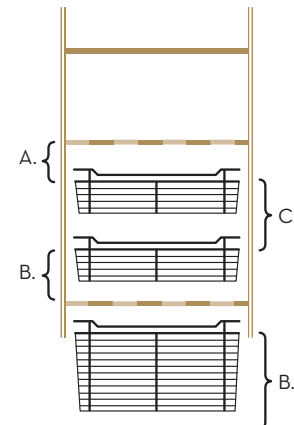

HAMPERS

TO INSTALL YOUR HAMPER:

- 1. INSTALL THE CAM SHELVES:**
 After hamper unit verticals are hung, install the cam shelves as specified in the diagram to the right:
- 2. ASSEMBLE HAMPER KIT & DOOR FACE:**
 Follow the steps in the graphic below to assemble the hamper kit and door face.

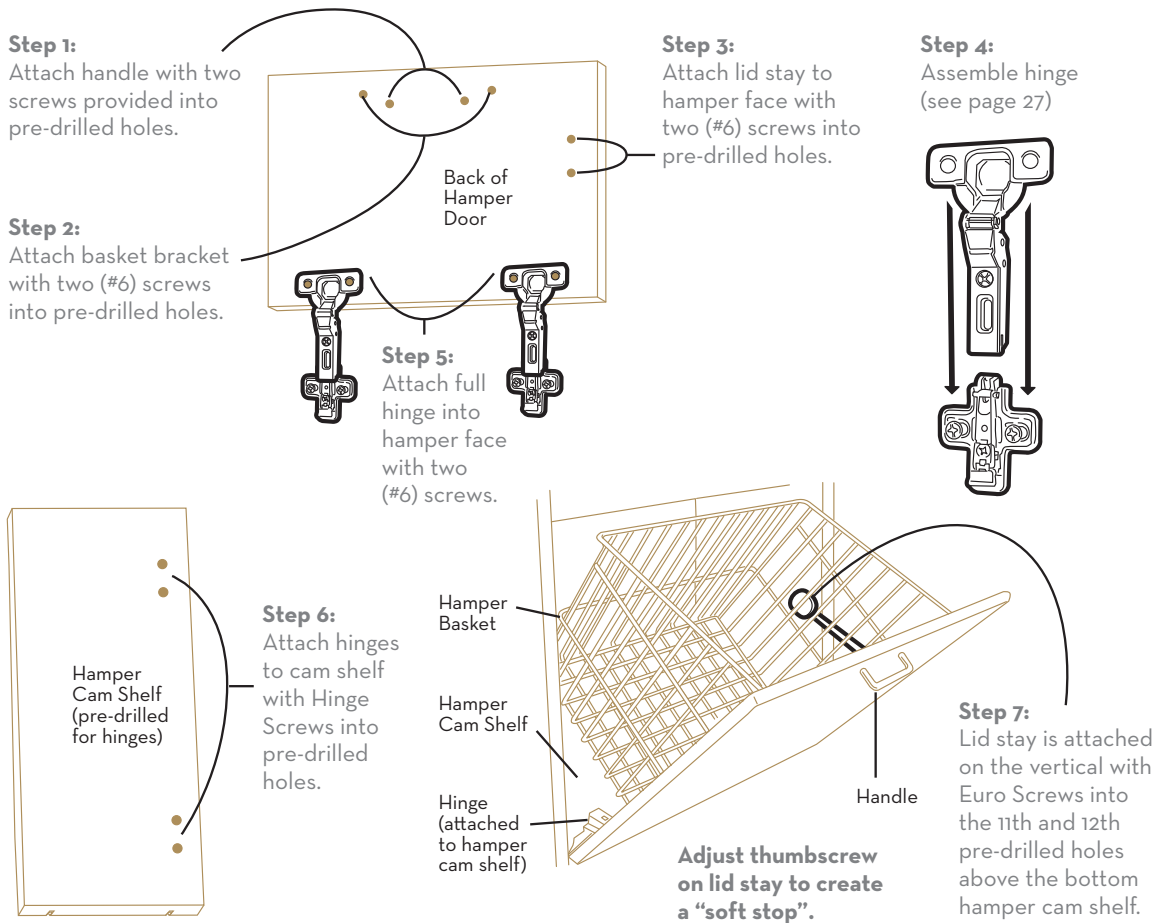
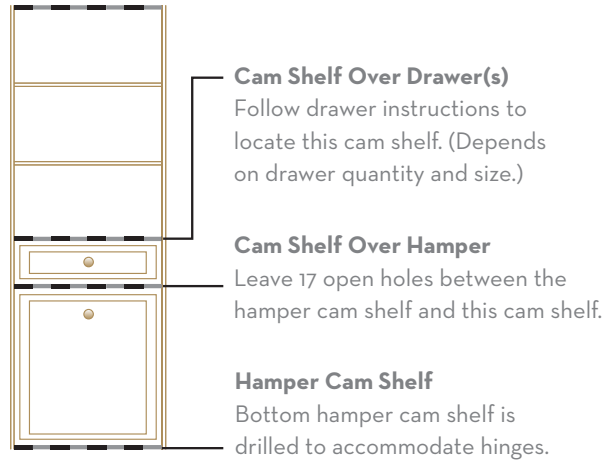

SLANTED SHOE SHELVES

TO ATTACH SLANTED SHOE SHELVES:

1. **Hang the vertical panels and install the top flat cam shelf.**
2. **Insert fences into the shelves.** Insert the fences into the pre-drilled holes in the front of the slanted shoe shelves. The vertical bars in the fence face the interior of the shelf. Use a mallet or a hammer with a protective wood block buffer piece to pound the fences into the shelves. Fences cannot be removed, once installed.

IF CAMMED SLANTED SHOE SHELVES ARE INCLUDED:

3. **Install bottom cam shelf.** For the lowest slanted shoe shelf, install a slanted bottom cam shelf with the front cams in the 2nd hole from the bottom and the back cams in the 5th hole from the bottom.
4. **Install middle slanted cam shelf.** For a typical full slanted shoe shelf installation, as shown below, install middle slanted cam shelf at the midpoint of the vertical. Refer to illustration below to establish the proper slope.
5. **Install adjustable slanted shelves.** Leaving 5 open holes between adjustable slanted shoe shelves, insert four shelf pins with the rear of the shelf raised to the 3rd hole above level.

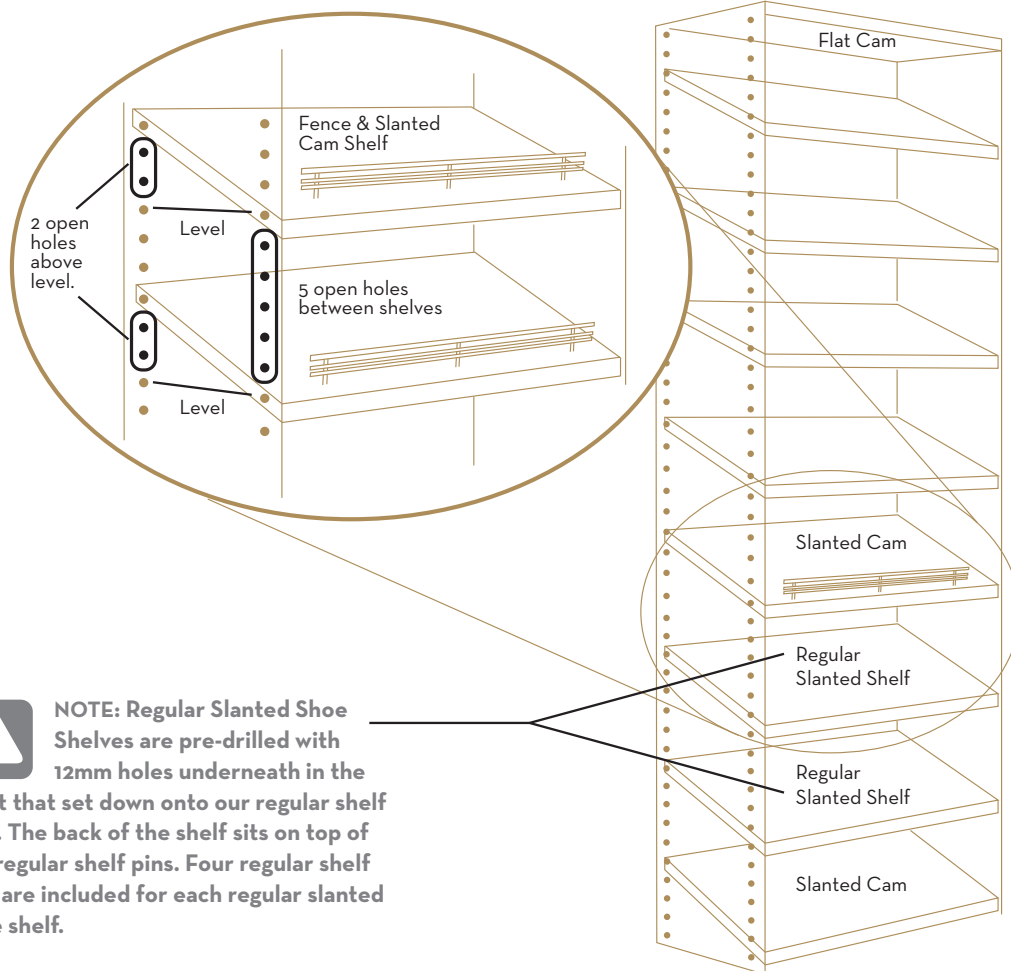

SHELF-MOUNTED IRONING BOARD

A. INSTALL IRONING BOARD CAM SHELF:

In most designs, the ironing board will be installed at the top of a stack of drawers. If so, skip to section B. Please note that the ironing surface will be 4" higher than the cam shelf to which it is mounted.

If the location is not predetermined, proceed as follows:

1. **Calculate Height:** Determine the desired height of the ironing surface and subtract 4".
2. **Install Cam Shelf:** Install the ironing board cam shelf in the pre-drilled vertical panel holes nearest to the height calculated in Step 1 as measured from the floor.

B. ANCHOR CAM SHELF:

IMPORTANT: Before mounting the Ironfix Shelf-Mounted Ironing Board, you must have installed your closet system correctly. In addition to the steel track and any required support cleats, you must secure the section containing the ironing board to the wall with an L-bracket.

1. Position the L-Bracket:

Position the L-bracket against the wall and the cam shelf. The L-bracket may be installed either above or below the ironing board cam shelf.

2. Attach the L-Bracket:

Attach the L-bracket to the shelf with 5/8" screws. Secure the L-bracket to the wall with a 2" screw into a stud or an E-Z Toggle.

C. REINFORCE CAM SHELF:

1. **Install Top Angle Brackets:** Install two angle brackets on the top and to the rear of the ironing board cam shelf with 5/8" screws as shown in the figure.
2. **Install Bottom Angle Brackets:** Install four angle brackets on the bottom of the ironing board cam shelf with 5/8" screws, two just behind the front cam fittings and two just in front of the rear cam fittings as shown in the figure.

D. INSTALL SECOND CAM SHELF:

Install a standard cam shelf above the ironing board cam shelf, leaving five open holes between the two shelves.

Figure for Step A.

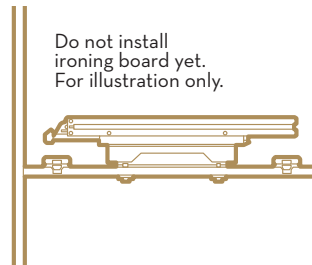
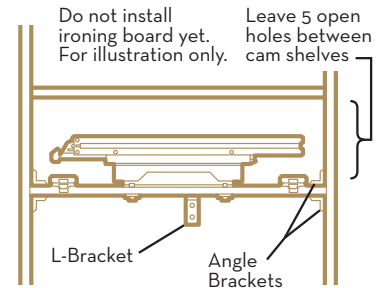
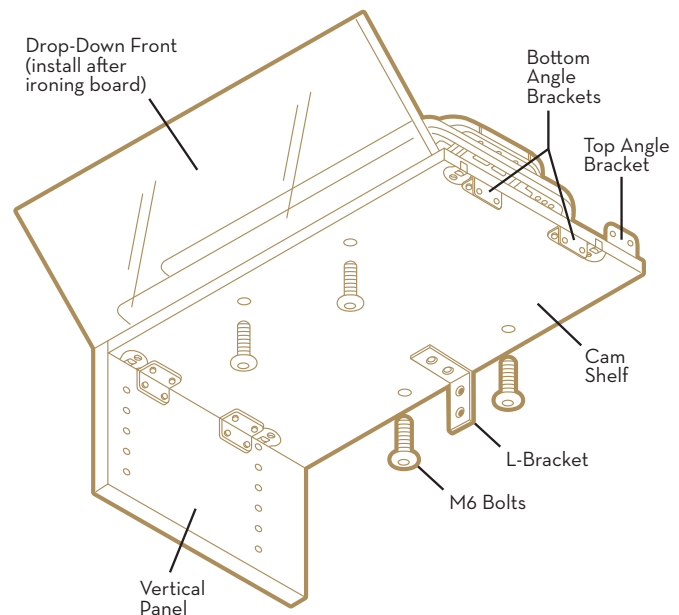

Figure for Step D.



INSTALL IRONING BOARD:

1. **Position Ironfix:** Place the Ironfix Shelf-Mounted Ironing Board with the logo to the front on the pre-drilled cam shelf, and align the four mounting holes on the Ironfix to those on the shelf.
2. **Attach Ironfix:** Attach Ironfix to shelf with four M6 bolts inserted through shelf from below.



SHELF-MOUNTED IRONING BOARD

ATTACH DROP-DOWN FRONT:

- 1. Assemble Hinges.** See figure.
- 2. Attach Hinges to Drop-Down Front.** Position hinges square to the edge of the drop-down front, and secure each hinge with two 5/8" screws. See figure.
- 3. Attach Drop-Down Front.** Position drop-down front so that hinges align with pre-drilled holes in cam shelf. Using a Phillips screwdriver, drive the four hinge screws into the cam shelf.
- 4. Attach Pull.** Attach handle or knob to the drop-down front with the screw(s) provided.
- 5. Adjust Hinges.** The drop-down front may be adjusted sideways by loosening the shelf plate mounting screws and sliding the shelf plate. Retighten the mounting screws in the desired position. Additional adjustments are possible by turning the hinge adjuster screws as described in the figure.

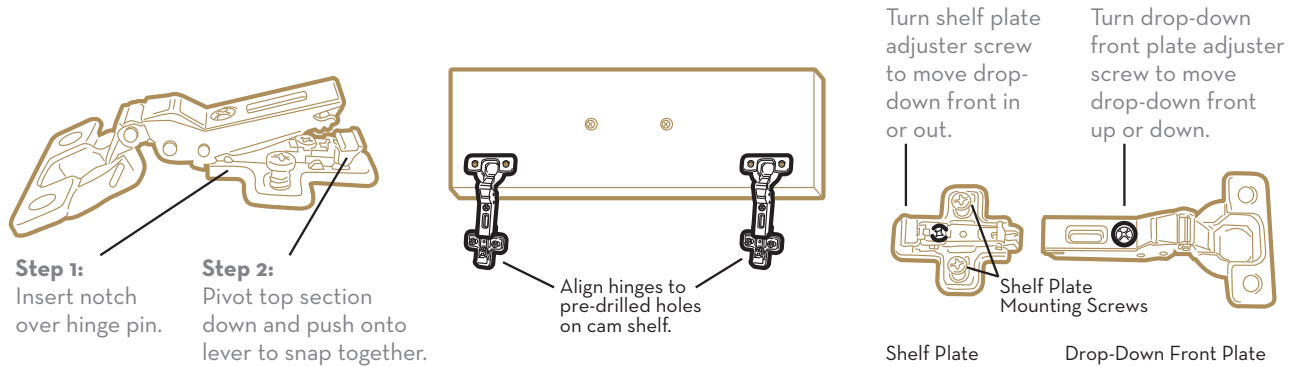

TO USE THE IRONFIX SHELF-MOUNTED IRONING BOARD:

- 1. Slide Out the Ironfix.** After opening the drop-down front, grasp the base and pull the Ironfix straight out. (See Figure 1.)
- 2. Open the Ironfix.** Lift the tapered end of the ironing board, opening the Ironfix like a book. (See Figure 2.)
- 3. Rotate to the Desired Position.** Rotate the board to any of the seven pre-set positions. (See Figure 3.)
- 4. Store the Ironfix.** Reverse steps 1 - 3 to store the Ironfix.

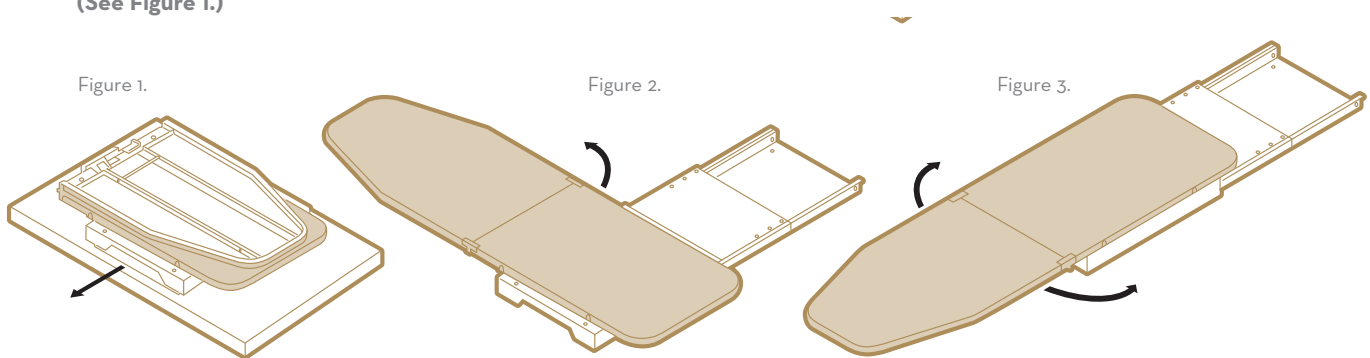

INSIDE & OUTSIDE CORNER SHELVES

NOTE: Install the inside radius corner shelf section before adjacent sections.

INSIDE RADIUS CORNER SHELVES

- Layout track:** Run right wall track into corner. Stop left wall track at least 15" short of the corner. It is best to have the end of the left wall track anchored in a stud. See figures.
- Hang vertical panels:** Hang the inside and two outside verticals 24" from the corner for 24" corner shelves and 30" from the corner for 30" corner shelves.

TIP: Install top cam screws before hanging panels, using single cam screws for the "inside" panel and double cam screws for the "outside" panels, if there are adjacent sections.

- Install cam screws:** After hanging panels, layout the positions for the middle cam shelf and regular shelves using one shelf pin for each shelf in position #3 or #4. See figure. When satisfied, install all cam screws for the middle and bottom cam shelves.
- Install cam shelves:** Install the top cam shelf first, followed by the middle and bottom cam shelves. Lower each cam shelf onto its cam screws. Lock each cam fitting with one-quarter turn clockwise using a #2 Phillips screwdriver.

TIP: Angle the shelves when installing, to make it easier to clear the installed cam screws.

- Insert shelf pins:** Insert five shelf pins for each shelf, leaving position #1 empty. See figure.
- Install regular shelves:** Angling each shelf, lift it above, then lower it onto its shelf pins, #2 thru #6. Finally, lift shelf slightly to insert shelf pin #1.

OUTSIDE CORNER SHELVES

IMPORTANT: The steel track must not extend beyond side vertical panel into space for back vertical panel.

- Mount Back Vertical Panel:** Mount back vertical panel against the back wall and flush perpendicular to side vertical panel.

Option A: Anchor to stud with three track screws, one at the top, one at the middle and one at the bottom of the vertical. To do this, locate the stud and mark its corresponding position on the "back panel". Drill 3/16" holes in the vertical panel at the intersections of the stud line and where cam shelves will cover screws. Hold "back panel" in position and drive screws into stud until they are flush or slightly countersunk.

Option B: Anchor to wall with toggle bolts. Install toggle bolts through pre-drilled vertical panel holes in locations other than where corner shelves will be positioned. Make sure the toggle bolts are tight!
- Install Corner Shelves:** Using single cam screws on the back vertical and single/double cam screws on the side vertical, install corner cam shelves. If corner shelves do not drawer tight to the vertical panels, then side and back panels are not perpendicular. In this case, loosen back panel anchor screws until corner shelves can be locked in place. Then insert shims near anchor screws and retighten.

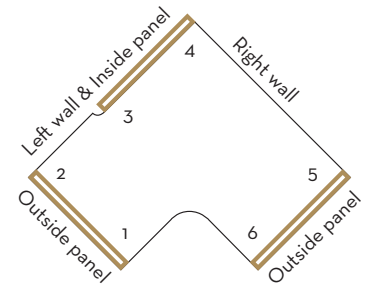
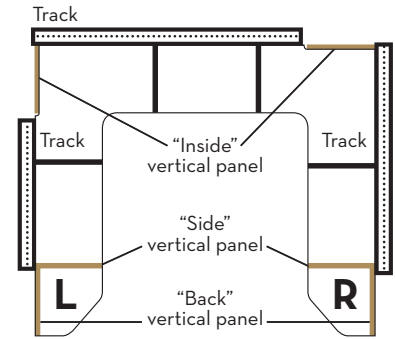

Inside radius corner shelf

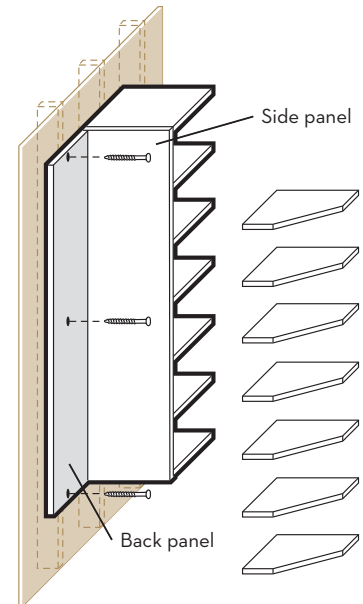

NOTE: Pre-drilled holes not shown.

CONNECTING SHELVES IN CORNERS

A. CONNECTOR BRACKET SYSTEM (TOP SHELVES ONLY)

The Connector Bracket System is used to join top shelves at a 90 degree angle. The Connector Cam Shelf, which is half-cammed, bridges the gap between the two adjacent shelf units. (See Figure 1.)

TO INSTALL CONNECTOR BRACKET SYSTEM:

1. **Attach Connector Brackets:** On the top non-cammed side of the shelf, use two (#6) 5/8" screws to attach connector brackets with a half overlap, approximately 2" from the front and back edge.
2. **Check Double Cam Screws:** Make sure that double cam screws are installed in the top set of holes of the side vertical panel. **You may be required to drill through the top holes if the end panel is finished.**
3. **Install Connector Cam Shelf:** Install the Connector Cam Shelf as shown in the diagram above. After locking the cams, make sure that the non-cammed side is flush with the receptor unit's top shelf. Secure the Connector Brackets using two (#6) 5/8" screws.

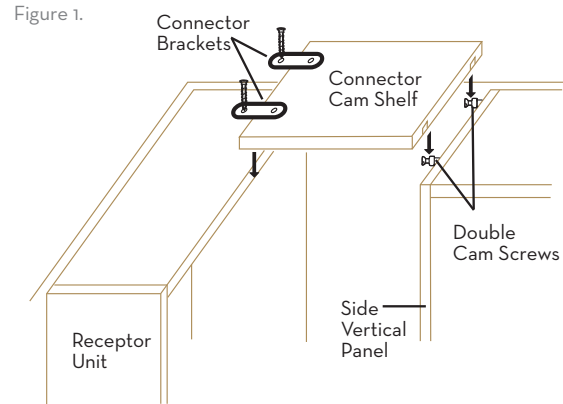

B. H-CHANNEL SYSTEM

The H-Channel System is used to join shelves at a 90 degree angle. These half-cam and regular shelves bridge the gap between the two adjacent shelf units. These shelves are usually 3/16" shorter than the width of the gap. (See Figure 2.)

TO INSTALL H-CHANNEL:

1. **Install H-Channel to Receptor Unit:** Install the H-Channel onto the front of the Receptor Unit cam shelf, as shown above. If necessary, trim length using a hacksaw.
2. **Install Double Cam Screws:** Screw double cam screws into the side vertical in the top set of holes. **You may be required to drill through the top holes if the end panel is finished.**
3. **Slide Half-Cam into H-Channel:** Slide the Half-Cam Shelf into the H-Channel and support the opposite side by locking into the cam fittings. Repeat steps 1 to 3 for additional shelves.
4. **Install Corner Brackets:** Install Corner Brackets against the 90 degree corner of the half-cam and receptor cam shelves by using two (#6) 5/8" screws, as shown above. Snap the flap shut.

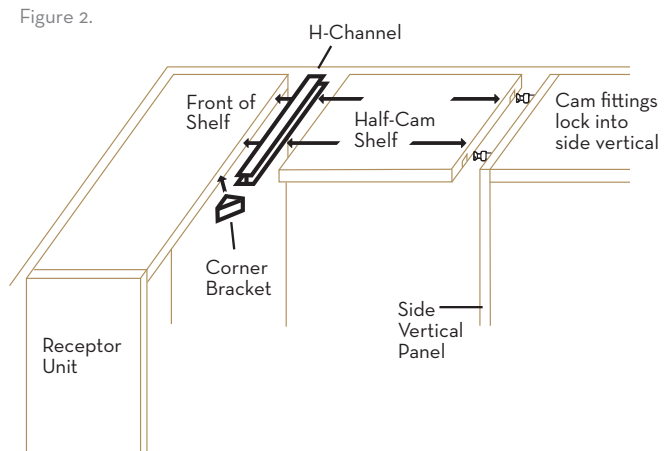

DOORS

Our doors are half overlay doors with European hinges. All doors are pre-drilled to receive our door hinges. We do not pre-drill for handles since handle location is based on personal preference.

ASSEMBLING HINGES & INSTALLING DOORS:

- 1. Assemble hinges:**
Assemble hinges using **Figure 1**.
- 2. Position door plate onto back of door.**
Make sure that the hinge is square to the edge of the door and not crooked.
- 3. Use two (#6) 5/8" screws to attach.**
- 4. Position the door.** Hold door against unit and position it so that the top and bottom cam shelves are partly covered by the door.
- 5. Attach cabinet plate.** Screw the pre-installed hinge screws on the Cabinet Plate into the closest pre-drilled holes at the front of the vertical.

INSTALLING THE HANDLES:

Determine door pull locations according to your preference, using other cabinetry in your home as a guide. If you have several pulls to install, consider making a template. Pre-drill the handle or knob hole(s) from the front side of the door using a 5mm or 3/16" drill bit. We recommend this drilling direction to avoid the drill bit from chipping out the material on the front side of the door. Clamp or hold a scrap board on the back of the door to minimize chip out when the drill bit breaks through. For handles, drill the holes 96mm on center.



NOTE: All custom doors will arrive 2-3 weeks after your order.

Adjusting Hinges:

The hinges can be adjusted slightly using screws A & B as noted in **Figure 2**.

Figure 1.

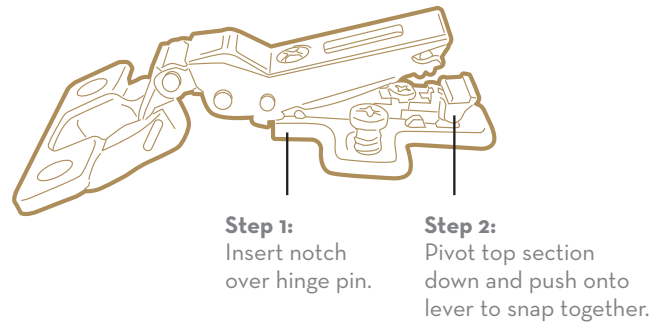
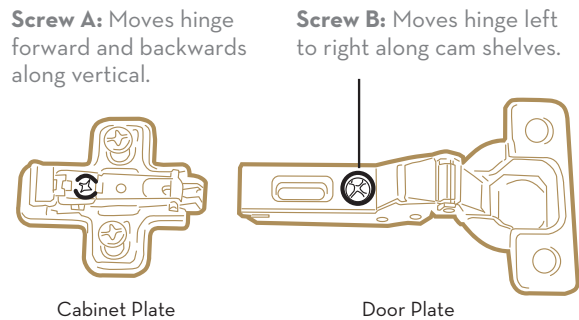

Figure 2.



CROWN MOLDING

TO INSTALL YOUR CROWN MOLDING:

- 1. Install Half-Cam Shelves:** Install Half-Cam Shelves to connect the top shelves of each unit. (See page 25.)
- 2. Determine Placement of Crown:** Determine placement of crown by marking the 1-1/2" setback along the entire section of the top cam shelves.
- 3. Cut Crown to Length:** Using a miter saw, cut to length.
- 4. Drill Pilot Holes:** Drill pilot holes through molding.
- 5. Secure Molding to Top Cam Shelves:** Using the 1" screws provided, secure molding to top cam shelves every 12".



PLEASE NOTE: Installation of Crown Molding requires trim carpentry skills and additional tools, such as a miter saw.

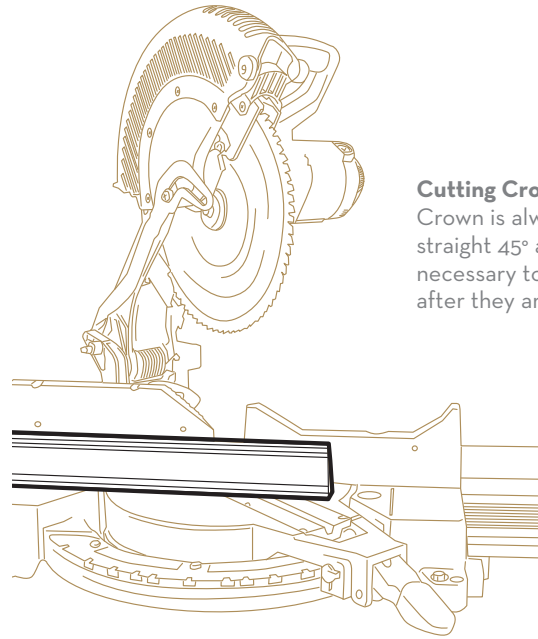

Cutting Crown Molding: Crown is always cut at a straight 45° angle. It is not necessary to cope pieces after they are cut.

Pilot Hole: Drill pilot hole through molding here and midway through top cam shelf.



BASE

NOTE:

When cutting, position the crown molding on the miter saw just as it will sit on the top shelf. The base of the molding should be flat on the saw table and the contoured face away from the saw fence. Start by cutting the piece a little long, then trim to fit.

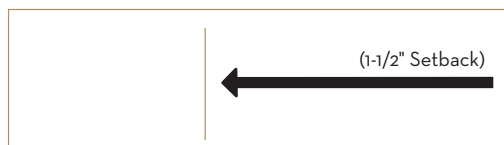

TOP CAM SHELF



TIP: Temporarily attaching a cleat at the 1-1/2" setback will make aligning and securing the crown molding easier.

PANTRY ITEMS

PULL-OUT WINE RACKS AND SPICE RACKS:

Pull-Out Wine Racks and Spice Racks are installed in a manner similar to pull-out wire baskets. Attach glides to vertical panels with Euro screws and hang racks on glide hooks at a height to suit your needs.

Pull-Out Wine Racks

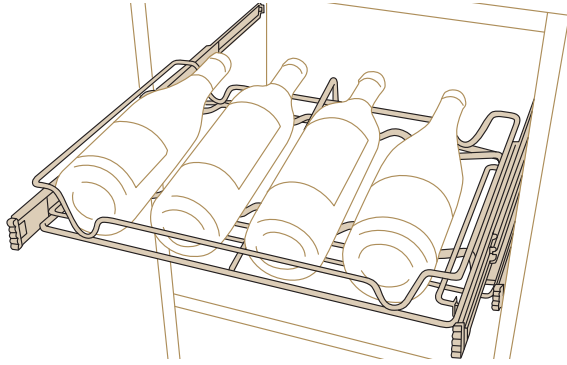

Spice Racks

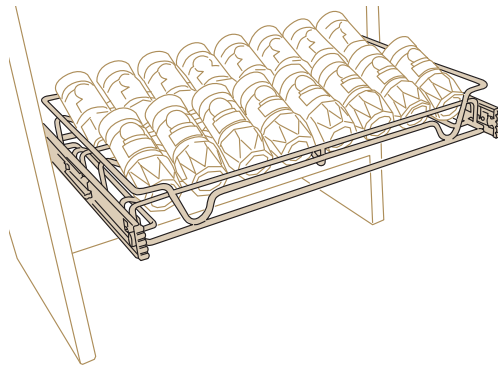

FIXED WINE RACKS:

Fixed wine racks are paired with a pre-drilled cam shelf and held in place with 25x5 mm pins.

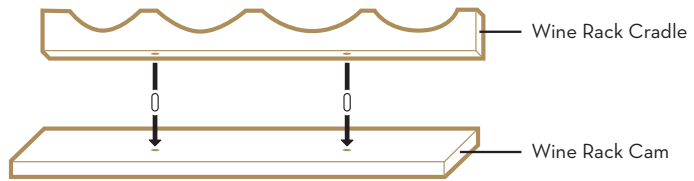

TO INSTALL GLASS RACKS:

Use 1-1/4" screws to install racks in bottom of cam shelf; then install the cam shelf into the unit.

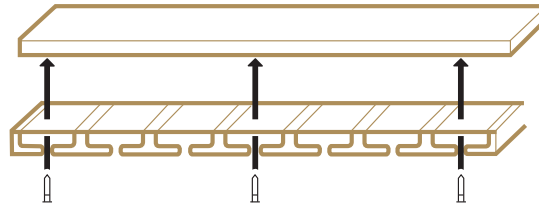

TO INSTALL TRAY DIVIDERS:

Tap 25x5 mm pins into pre-drilled holes inside both upper and lower cam shelves. Install cam shelves with 17 open holes in-between. Slide grooved 22-1/2" tray dividers over pins.

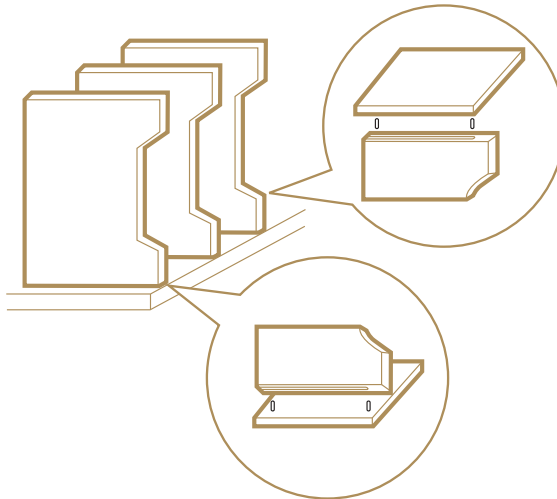

NON STANDARD INSTALLATIONS

POCKET DOORS

1. **Draw Level Line for Track:** Draw track level line for all wall units at a minimum of 75-5/8" from the floor.
2. **Attach Track:** Attach track over the pocket door recess, into the furring strips, using 1-1/4" screws.
3. **Install Cleat into Header:** After installing the unit(s) over the pocket door recess on the track in the normal manner, install provided cleat flush to the underside of the top cam shelf. Using track screws, attach cleat into the door header, attaching it at the center and near both ends.
4. **Install Cleat Beneath Unit:** Position provided cleat beneath vertical panels and screw into furring strips using 2" screws.
5. **Attach Unit to Cleat:** Attach unit to cleat by drilling 3/16" diameter holes near the rear edge of the bottom cam shelf and driving 2" screws down into cleat.

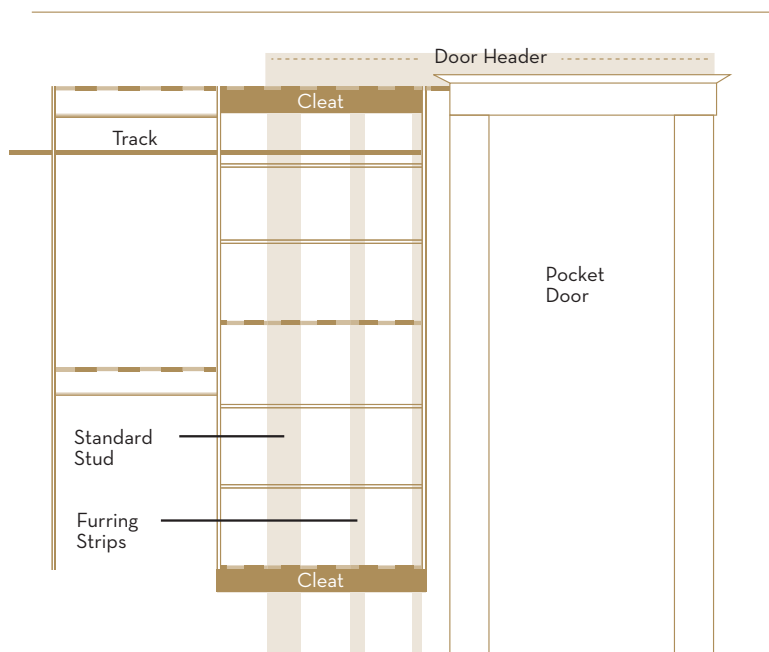

SLOPED CEILINGS

This installation requires tracks installed at different heights. It may help to have an assistant or clamps to hold parts for this installation. It is critical that the holes on all verticals are consistently level throughout the wall installation. Otherwise, the shelving will not be level. It helps to remember that the top of the vertical panel is always $8\text{-}\frac{3}{8}$ " above the bottom edge of the track. You can confirm this by holding a piece of track in the vertical panel notch.

TO INSTALL UNDER A SLOPED CEILING: In a typical installation, we recommend the following steps:

1. **Install highest section:** Start with the highest section. Install the track, verticals and cam shelves.
2. **Layout and install the next section:** Hold the vertical panel along with a shelf from the next section against the installed vertical panel, at the highest possible position accommodating the level shelf. With the vertical panels side-by-side, lower the free vertical panel until its holes are aligned with the installed vertical panel's holes. Mark the top of the free vertical panel, measure down $8\text{-}\frac{3}{8}$ " from this point and install the next track at this level.
3. **Repeat for each stepped down section.**

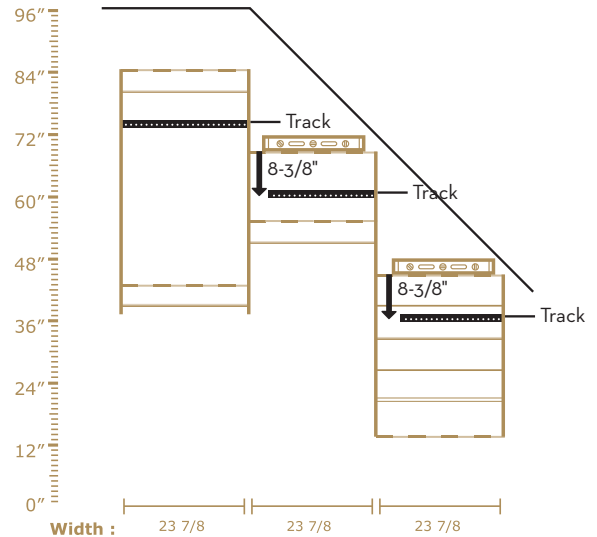

CLEATS FOR DEEP & TALL SECTIONS

All wall-mounted units over 14" deep or taller than 78" must be cleated for additional support. A cleat is $2\text{-}\frac{1}{2}$ " high and the full width of the unit(s) to be cleated. Some custom designed units may also require cleating, which will be noted either in the "Notes" section of your invoice or marked on your wall plans.

1. **Install unit(s) to be cleated:** Install unit(s) to be cleated using the Basic Installation Instructions at the beginning of this manual. Use a level to ensure the sides are plumb.
2. **Attach cleat to wall studs:** Position the cleat flat against the wall beneath the unit. The cleat must be in contact with the bottom of the vertical panels. Attach cleat to wall studs using track screws or toggle bolts.

(STEPS 3 & 4 ARE OPTIONAL)

3. **Pre-drill holes in bottom cam shelf:** Drill $\frac{3}{16}$ " diameter holes near the rear edge through the bottom cam shelf only.
4. **Attach unit to cleat:** Attach unit to cleat with 2" screws, driving them through pilot holes in cam shelf into cleat. If there is no cam shelf at the very bottom of the vertical panels (which can occur with pull-out baskets), you can secure the bottom-most cam shelf to a stud in the wall with an L-bracket.

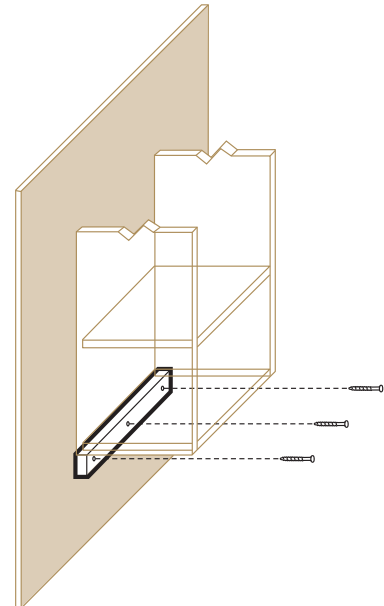

CLEATS FOR UNITS WITH SHORT VERTICAL PANELS

All wall-based units with only 24" vertical panels or shorter must be cleated to hold the top of the unit to the wall. The cleats will be 2-1/2" high and equal to the shelf widths.

1. **Install unit(s) to be cleated** following the Basic Installation Instructions.
2. **Position the cleat** against the wall just below the top cam shelf.
3. **Locate studs and drill 3/16" holes** through cleat for screws or toggle bolts.
4. **Anchor cleat** into wood studs with 2" screws or using E-Z Toggles if no studs are present.
5. **Anchor the top cam shelf to the cleat** with 2" screws through 3/16" thru-holes which you must drill near the rear of the top cam shelf.

Alternatively, you may screw the top cam shelf to the cleat first, before installing the shelf, and then anchor the cleat to the wall.

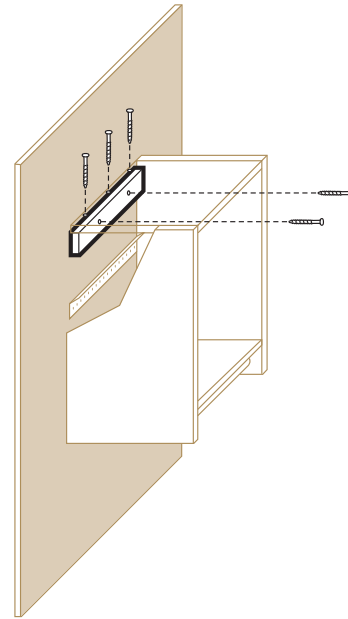

SURROUNDING WALL OBJECTS

Due to the custom nature of installing around wall objects, finished end panels are provided which require some on-site drilling. Surrounding wall objects may also require multiple track heights.

1. **Drill holes through the finished side of the vertical:** If a shared vertical is noted as having a finished side, carefully determine where "thru-holes" are required.

Method A: Place finished side down on a scrap board and drill thru the appropriate 5 mm holes. Some chip-out is possible.

Method B: Place finished side up and carefully position a thru-drilled panel on top so the holes will be aligned, and use the thru-drilled panel as a template to drill 5 mm holes where required.

Shared Vertical Panel: Holes drilled on left side and finished (no holes) on right side.

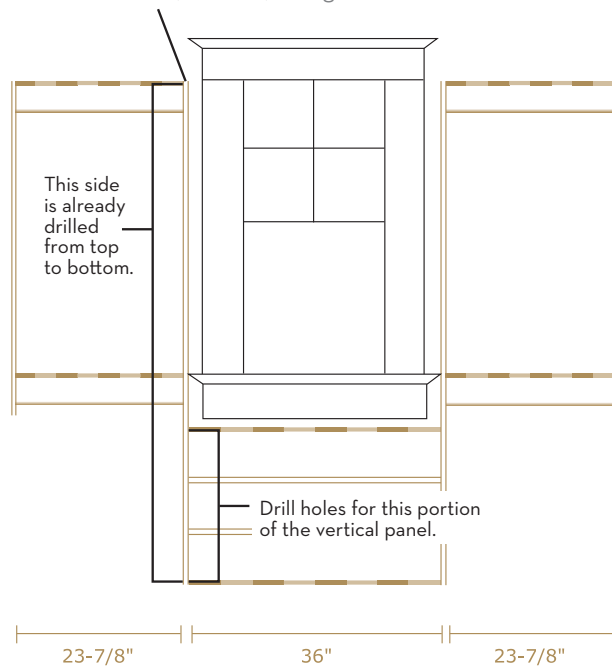

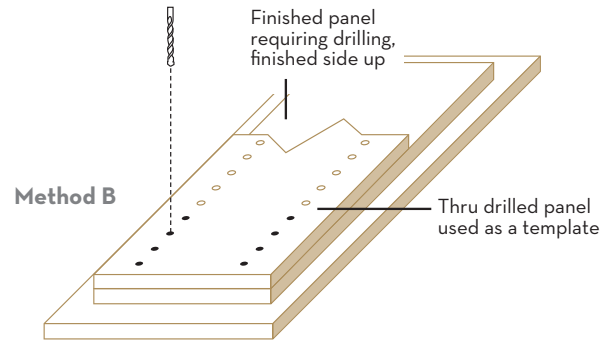
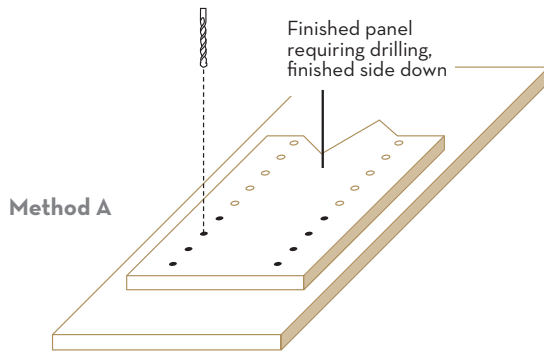

FINAL STEPS

ADJUSTABLE SHELVES

Simply insert shelf pins where desired and rest adjustable shelves on them.



TRACK COVER

NOTE: All track cover is white. The cover is usually concealed by items stored on the shelves and hanging rods, and it is paintable.

1. **Cut track cover to length:** Using the interior measurements of each unit, cut the track cover to length with a hacksaw.
2. **Slip cut sections into place:** Slip these sections into place over the track.



VERY IMPORTANT: Never hang vertical panels on top of the track cover. This will cause the notches to crack.

ACCESSORIES

Belt and Tie Racks

Installation instructions are included within the box. Best placement of racks are either within hanging units located directly below the rod, or against an outside vertical panel of a unit.

Valet Pole

Secure to vertical panel using four Euro Screws. Best placement is within or against a shelf unit at a minimum of 65" from the floor.

RODS

1. **Install rod end pairs:** Install rod end pairs per design, leaving one open hole between rod end and cam shelf above.
2. **Insert pre-cut rods into rod ends:** The fit should be tight but still allow for adjustment.

Install rod end pairs per design, leaving one open hole between rod and cam shelf above. No screws are required.

Insert pre-cut rods. Fit will be snug. Short rods may be trimmed with a hacksaw if difficult to install.

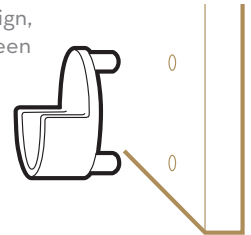

Belt Rack

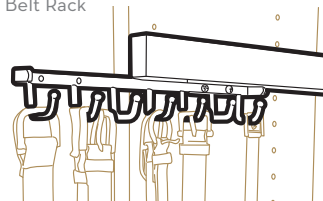

Valet Pole

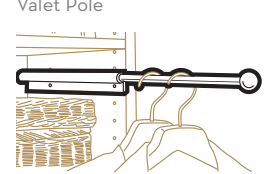

VERTICAL PANEL WORKSHEET

The common size vertical panels shown on this page are drawn to scale, including the correct number of 5 mm holes. Use these diagrams to lay out your components and better understand the 32 mm system. Mark the holes where cam screws, drawer & basket glides and rod ends are required. Every fifth hole from the bottom of each panel is marked for your convenience. [Print more copies of this worksheet from our online installation manual.](#)

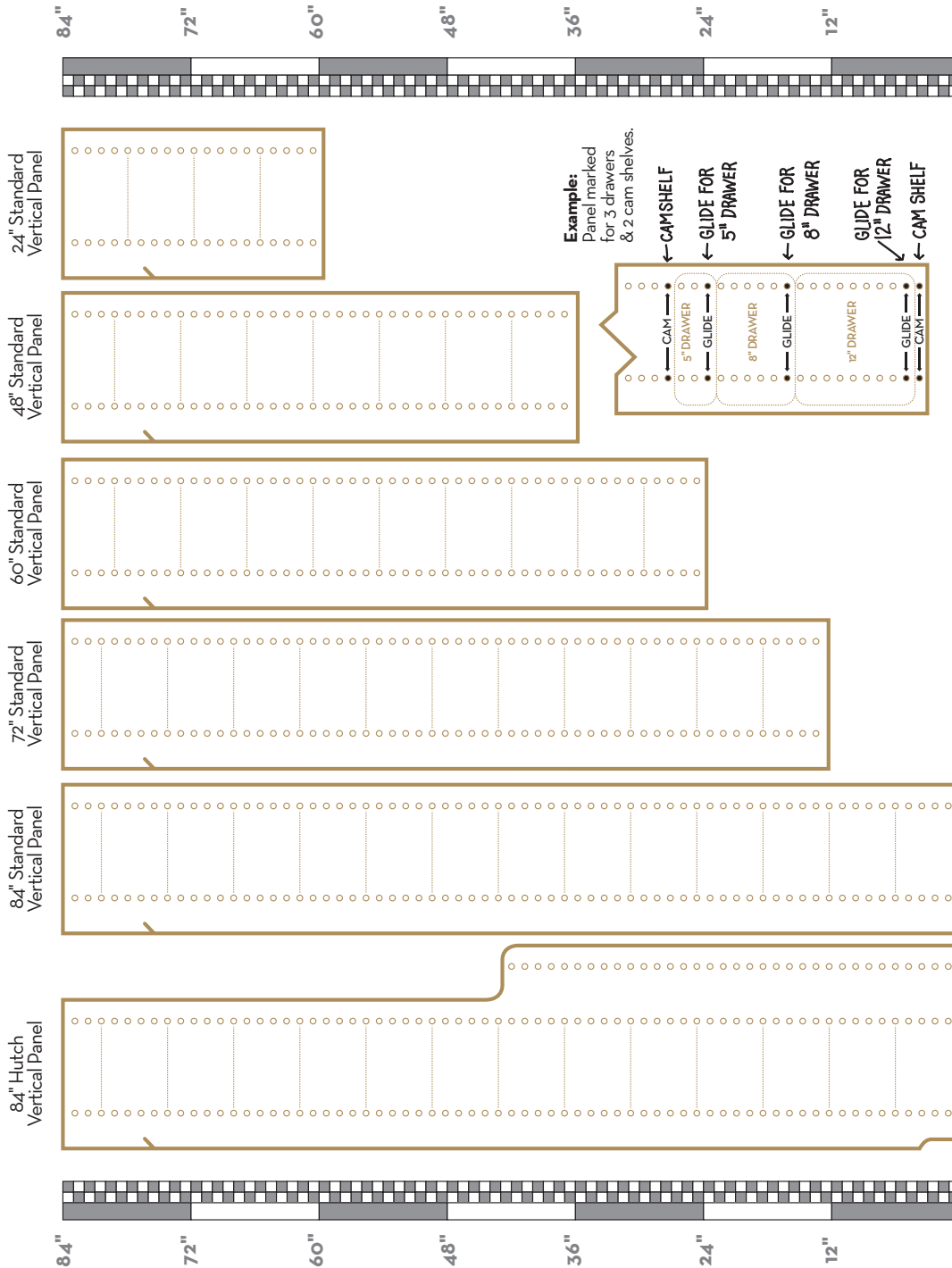



CUSTOMER SUPPORT

HAVE ANY QUESTIONS?

Give us a call 1-800-910-0129

Monday to Thursday: 8:00 AM to 7:00 PM E.S.T.

Friday: 8:00 AM to 5:00 PM E.S.T.

Saturday: 10:00 AM to 4:00 PM E.S.T.

IDEAS? COMMENTS?

E-Mail to: production@easyclosets.com

EasyClosets
19 Chapin Road, Building D
P.O. Box 2020
Pine Brook, NJ 07058